

OPERATING MANUAL

Reverse Osmosis Equipment
Model: Compact

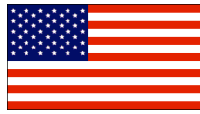

Made in U.S.A.

TABLE OF CONTENTS:

SAFETY INSTRUCTIONS	Page 1
INSTALLATION GUIDELINES AND REQUIREMENTS	Page 2
COMPACT R. O. SYSTEM INSTALLATION	Page 3
SYSTEM PRE-START AND START CHECKLIST	Page 6
GENERAL MAINTENANCE	Page 8
IMAGE OF REVERSE OSMOSIS SYSTEM (front view)	Page 9
IMAGE OF REVERSE OSMOSIS SYSTEM (back view)	Page 10
WIRING DIAGRAM	Page 11
ITEMIZATION OF COMPONENTS	Page 12
TROUBLE SHOOTING GUIDE	Page 14

SAFETY INSTRUCTIONS

- 1) Read this manual before installing system.
- 2) Electrical connection should be made by a licensed electrician or qualified person that can make all connections to code.
- 3) Check that the proper-sized breaker(s) is used to prevent possible fire risk.
- 4) All water connections should be made by a licensed plumber or qualified person that can make all connections to code. This system must be grounded.
- 5) Make sure that all electrical connections will not become exposed to water in case of leaks or possible rupture in water lines due to pressure spikes, possible component failure, etc.
- 6) Give the area around the system plenty of room for servicing and general maintenance. Allow for plenty of ventilation in the room where the system is placed. Some installations may have to be made where the system is placed outside. It is advisable to construct a small box around the system to protect it from the elements.
- 7) The water supply should be turned off before servicing.
- 8) Save these instructions for future reference.

INSTALLATION GUIDELINES AND REQUIREMENTS

ELECTRICAL REQUIREMENTS: A label identifying the voltage requirement is affixed to the junction box where the power cord connects. The voltage will be either "220v or 110v" and "50HZ or 60HZ".

WATER SUPPLY: A minimum of a 1/2" copper or PVC pipe leading close to the COMPACT R. O. System as possible. From there, feed line requirements to the system vary depending on system size:

- 150, 250, 450 gpd models, use 3/8" polyethylene tubing
- 800 gpd model, use 1/2" polyethylene tubing

DRAIN: The drain for R. O. waste water can be one of the following:

- Floor sink
- Standard household or commercial ABS drain line (accessible)
- Leach field - used only if local laws allow waste discharge from an R. O. to be drained into a leach field.

FEED WATER CONNECTION: The conditions of the feed water should not contain more than 2,000 TDS (Total dissolved Solids)

- Turbidity free
- Silica level @ 25 ppm maximum
- Iron level @ .05 maximum
- Free of hydrogen sulfide
- Feed water temperature 85°F maximum
- Feed water pressure 40 - 80 psi
- Operating pressure 200 psi maximum
- Feed water TDS 2000 ppm maximum
- pH range 3 - 11
- Turbidity should be removed
- Iron tolerance 0.5 ppm maximum
- Hydrogen sulfide must be removed
- Silica tolerance 25 ppm maximum @ 50% recovery

COMPACT R. O. SYSTEM INSTALLATION

The following is a typical installation procedure for installing the COMPACT R. O. System in a normal application. There may be other procedures for installing the COMPACT R. O. System, since the application varies for R. O. system use (such as pre-treatment, post-treatment, reclaim and processing). Consult factory if there are any special circumstances for installation.

NOTE: Installation connections such as feed water, tank adaptors, tank fittings, 220v electrical plugs, drain clamps, tubing, and misc. accessories are not included with the COMPACT R. O. System due to many types of installations. These are common items found at your local hardware or electrical supply store.

Decide where the COMPACT R. O. System is to be placed, keeping in mind that sufficient space is available to service the system. There must be ample space around the system for heat dissipation from the motor. A drain must be accessible. Feed water must be accessible. Electrical supply must be available.

ELECTRICAL REQUIREMENTS:

- 110v: The COMPACT R. O. System uses very little current for operation. If designed for 110v power supply, the COMPACT R. O. System can be plugged into any household outlet receptacle.
- 220v: If the COMPACT R. O. System was specified to be built for a 220v power supply, you will need to supply your own 220v plug (can be purchased at a local hardware store or electrical parts supplier). Install the 220v plug onto existing power cord of the COMPACT R. O. System.
- Have a licensed electrician run conduit for a power supply and connect to the COMPACT R. O. System, if the system is to be hard-wired.

FLOAT SWITCH CONNECTION (optional)

The float switch (if supplied) is a non-mercury style liquid-level switch. The switch is supplied with a piggy back plug.

For 110v power requirements, the COMPACT R. O. System plugs directly into the piggy back plug of the float switch. The other side of the piggy back plug, plug into 110v outlet.

For 220v power requirements, the piggy back plug must be cut-off of the float switch cord. Then, follow the instructions supplied with the float switch carton.

FEED WATER CONNECTION

The feed water fitting is to be installed by the installer. The connection is made at the inlet of the pre-filter. Use polyethylene tubing from feed water supply and connect to inlet fitting of COMPACT R. O. System. Make sure that a tubing insert is used as tubing support.

3/8" OD tubing should be used for 150, 250, 450 gpd models.

1/2" OD tubing should be used for 800 gpd model.

NOTE: If there is a considerable distance from the COMPACT R. O. System to feed water supply, it is best that 1/2" copper or PVC is used to bring the water supply as close to the COMPACT R. O. System as possible. This will help eliminate a potential cycling problem due to insufficient water pressure or volume supplies. Make sure that a shut-off is located at the end of the piping for turning off water supply to the COMPACT R. O. System. It is acceptable to remove plastic inlet fitting to be removed and hard plumbed into filter inlet.

DRAIN CONNECTION

Use 3/8" polyethylene tubing from drain (waste) water connection on the COMPACT R. O. System to drain. Make sure that a tubing insert is used as a tubing support. CAUTION: Failure to use polyethylene tubing can result in possible leaks.

- Connect drain (waste) line according to local codes if using a floor sink.
- A drain saddle may be used if connecting drain line to a typical sink drain.
- The drain (waste) water from the COMPACT R. O. System should not be elevated more than necessary (maximum 10 feet). If drain line is elevated, use a 2 PSI, or less, check valve so the waste water does not return back to the COMPACT R. O. System. This will help prevent contamination, in case of sewage back-up.

PRODUCT WATER CONNECTION (pressurized or atmospheric storage "open storage")

Use 3/8" polyethylene tubing from COMPACT R. O. System to storage tank. Make sure a tubing insert is used as a tubing support. Install into tubing and tighten. CAUTION: Failure to use polyethylene tubing can result in possible leaks.

PRODUCT WATER CONNECTION (Pressurized storage)

If the COMPACT R. O. System was purchased with pressure switch operation, the system will be set-up for that purpose. When the pressure in the product water line reaches 50 PSI (or field re-adjusted pressure setting), the product pressure switch on the COMPACT R. O. System will turn the COMPACT R. O. System off. It will then turn back on when the pressure in the product water line drops to approximately 30 PSI, re-filling the pressurized storage tank. When using a pressurized storage tank (bladder tank), make sure that the tank is approved for reverse osmosis or purified water use. The diaphragm pressure should be set to about 15 PSI. NOTE: Some tanks are supplied with galvanized inlet fittings. These galvanized fittings will deteriorate when subjected to reverse osmosis or purer waters. Replace these fittings with PVC.

Use a T-connection on the pressurized tank. One side of the T-connection will be connected with polyethylene tubing from product water of the COMPACT R. O. System. The other side of the T-connection will be used as a connection to P.O.U. (Point Of Use) after post-filtration.

PRODUCT WATER CONNECTION (Atmospheric (open) storage tank)

If your COMPACT R. O. System was purchased for float switch operation, there will be a float switch supplied for this operation. Read all instructions regarding this float switch for proper set-up and understanding of float switch operation. If you do not use the float switch provided,

the COMPACT R. O. System will not turn off and will overflow the storage tank, causing flood damage.

When using an atmospheric storage tank, connect 3/8" polyethylene tubing from product connection to the upper portion of tank. Use a bulkhead (tank adaptor) for making this connection. Make sure that the connection is not higher than float switch shut-off level. Follow directions enclosed in float switch carton for operation. CAUTION: Failure to use polyethylene tubing can result in possible leaks.

SYSTEM PRE-START AND START CHECK LIST

After the COMPACT R. O. System connections have been made, including the post-treatment and dispensing mechanism, a Checklist has been provided to review that all required steps have been followed:

Feed water connection has been made and secured.

_____ Drain connection has been made and secured.

_____ Product from COMPACT R. O. System has been made to storage tank and secured.

_____ Float switch (if applicable) is installed into tank, adjusted and secured.

_____ Post-treatment installed, plumbed, and secured, including faucet and post-filters.

_____ Necessary shut-off valves installed on feed water supply, storage tank, etc., and turned-off.

_____ Install pre-filters into the COMPACT R. O. System in order, according to the COMPACT R. O. System diagram legend.

_____ Turn water supply on from feed water connection and check for any leaks on all pre-filters for the COMPACT R. O. System.

_____ Connect COMPACT R. O. System to electrical supply and turn power on. At this time, the inlet solenoid valve will open and allow water to enter into the pump. After the pressure stabilizes throughout the COMPACT R. O. System, it will start to run. The COMPACT R. O. System may start and stop a few times. If the COMPACT R. O. System continues to start and stop, disconnect power and refer to the trouble shooting guide.

_____ When the COMPACT R. O. System continues to run, observe system pressure gauge. If the pressure exceeds 200 PSI, adjust the pressure relief valve located on the pressure pump. *****200 PSI MAXIMUM*****. If your COMPACT R. O. System has been equipped with an automatic hourly flush feature, pressure adjustments must NOT be made during flushing cycle.

_____ Check to ensure water is running to drain.

_____ Check to see if product water is coming from the membrane. This can be done at the R. O. membrane or the storage tank.

_____ (if pressurized storage tank application) Turn off valve at pressurized storage tank and dispensing faucet. At this time, pressure will begin to build. The COMPACT R. O. System should shut off after a while. A gauge could be

installed in product or post-treatment water lines to check system ON and OFF pressures. The product water must fill all post-treatment and associated lines. This will determine how long it will take to pressurize and shut-off the COMPACT R. O. System. Water should discontinue to run to storage tank and drain. Once the COMPACT R. O. System shuts off, check all post-treatment water lines, filters, etc.

_____ (if atmospheric storage tank application) Allow the COMPACT R. O. System to run. Raise float switch inside the storage tank and check for system shut-off. Water should discontinue to run into tank and drain line.

_____ Turn storage tank shut-off to the ON position.

_____ Turn off feed water supply and check the COMPACT R. O. System for low water pressure shut-off.

_____ Turn water supply back on.

_____ Instruct customer about all shut-off valves and electrical disconnections. Also, tell customer that the storage tank will take some time to fill. Once storage tank is full, the post-filter should be rinsed before using the water.

GENERAL MAINTENANCE

- **PRE-FILTERS:** There are two gauges mounted on the pre-filters. These gauges measure the water pressure before and after the pre-filters. When there is a drop 10 - 15 psi difference of pressure readings between the two gauges, the pre-filters are getting clogged and must be changed.
- **R. O. MEMBRANE:** The quality of the product water should be checked periodically for rejection of total dissolved solids (TDS). When the rejection is below desired limit, the membrane should be changed or cleaned.
- **MISCELLANEOUS:** The operation of the pressure switches should be checked at least once a year for proper operation.
- **PUMP:** The pressure pump is a single-stage vane pump and has carbon impellers to increase the water pressure. Over time, the impeller may begin to wear. Adjustments can be made to the pressure relief on the pump to bring the pump back to desired operating pressure. If the impellers are too worn, the pressure relief adjustment will have little or no effect on system pressure. If this occurs, the pump must be replaced.

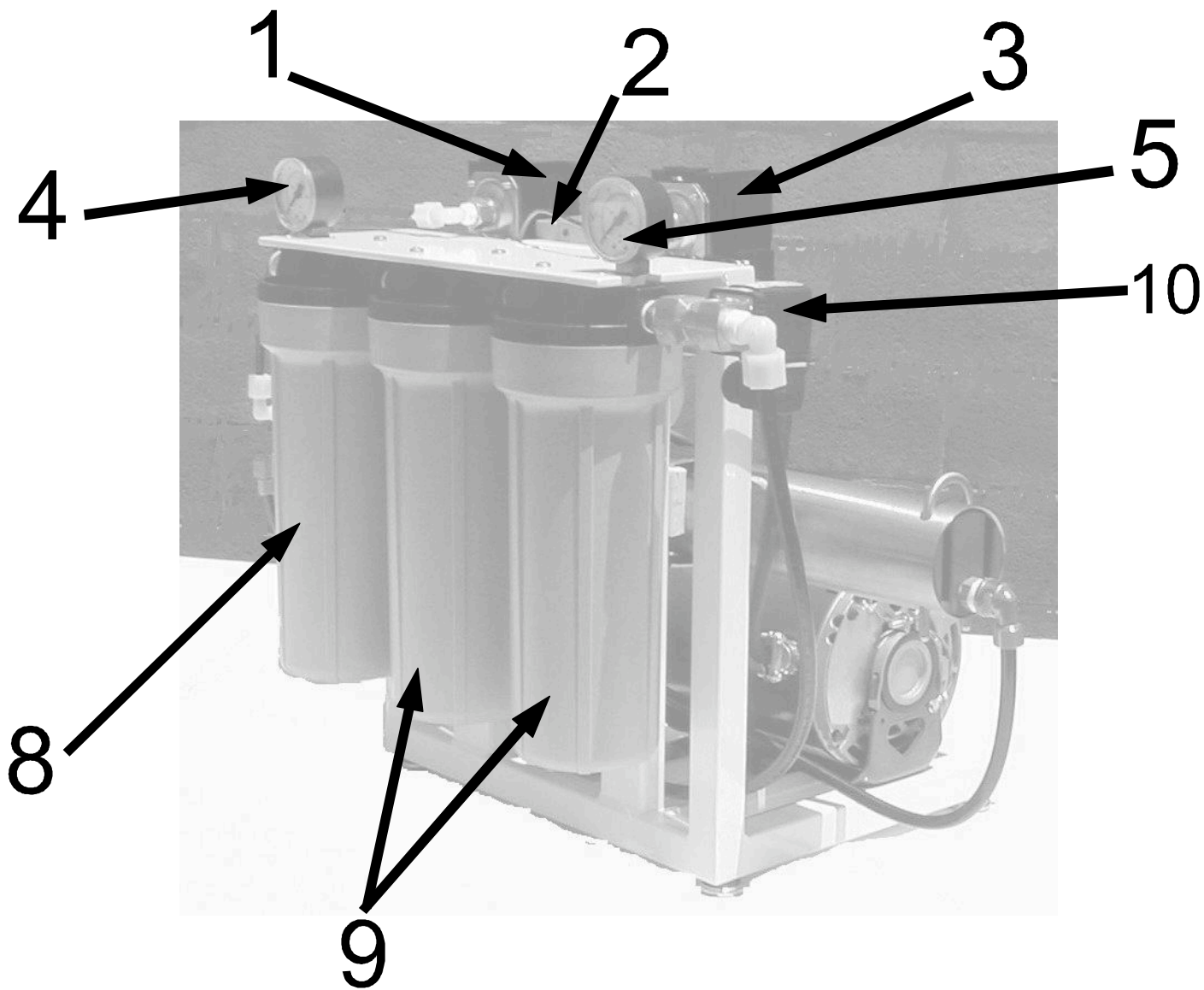

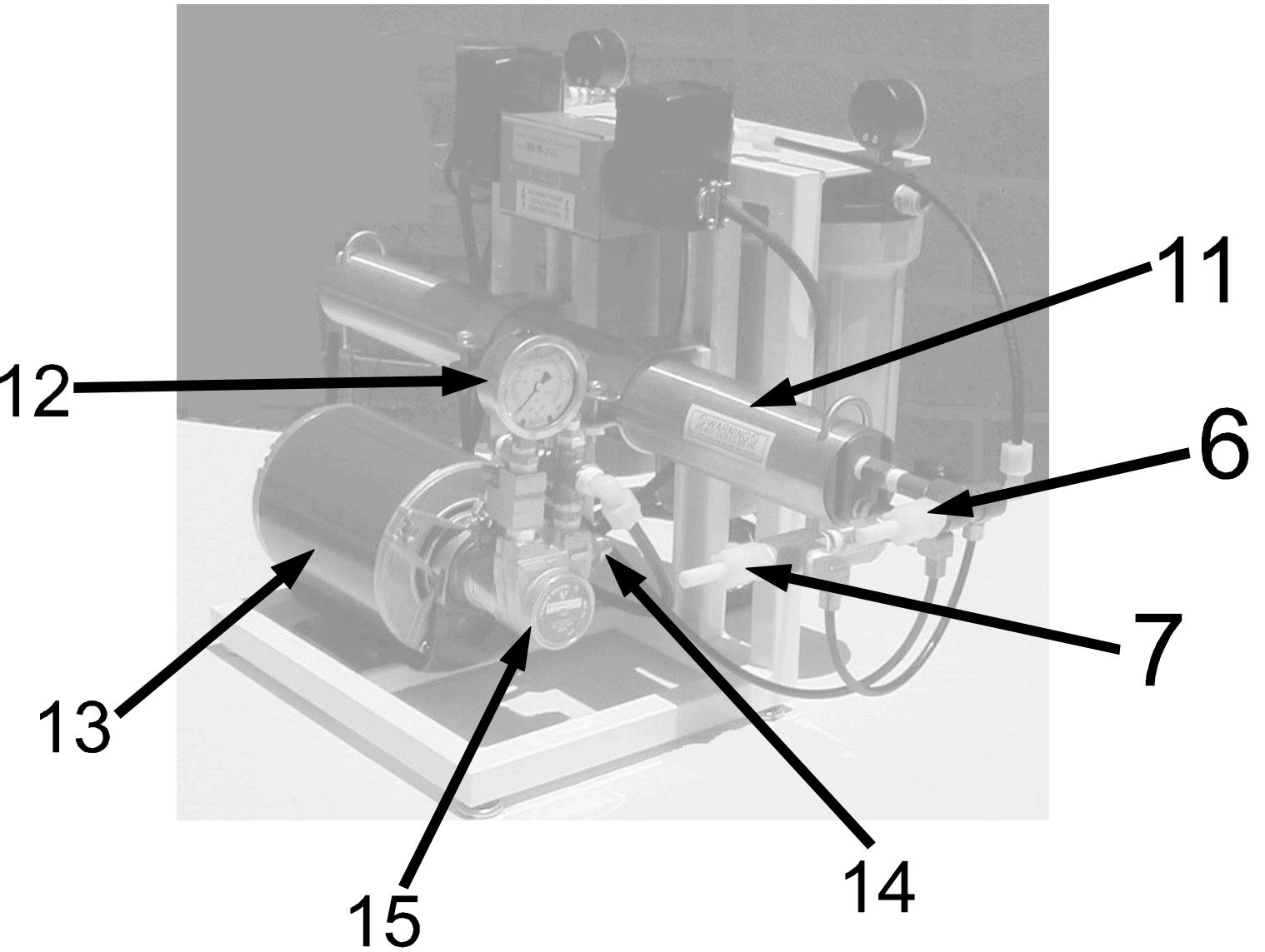

COM & COM-II WIRING DIAGRAM

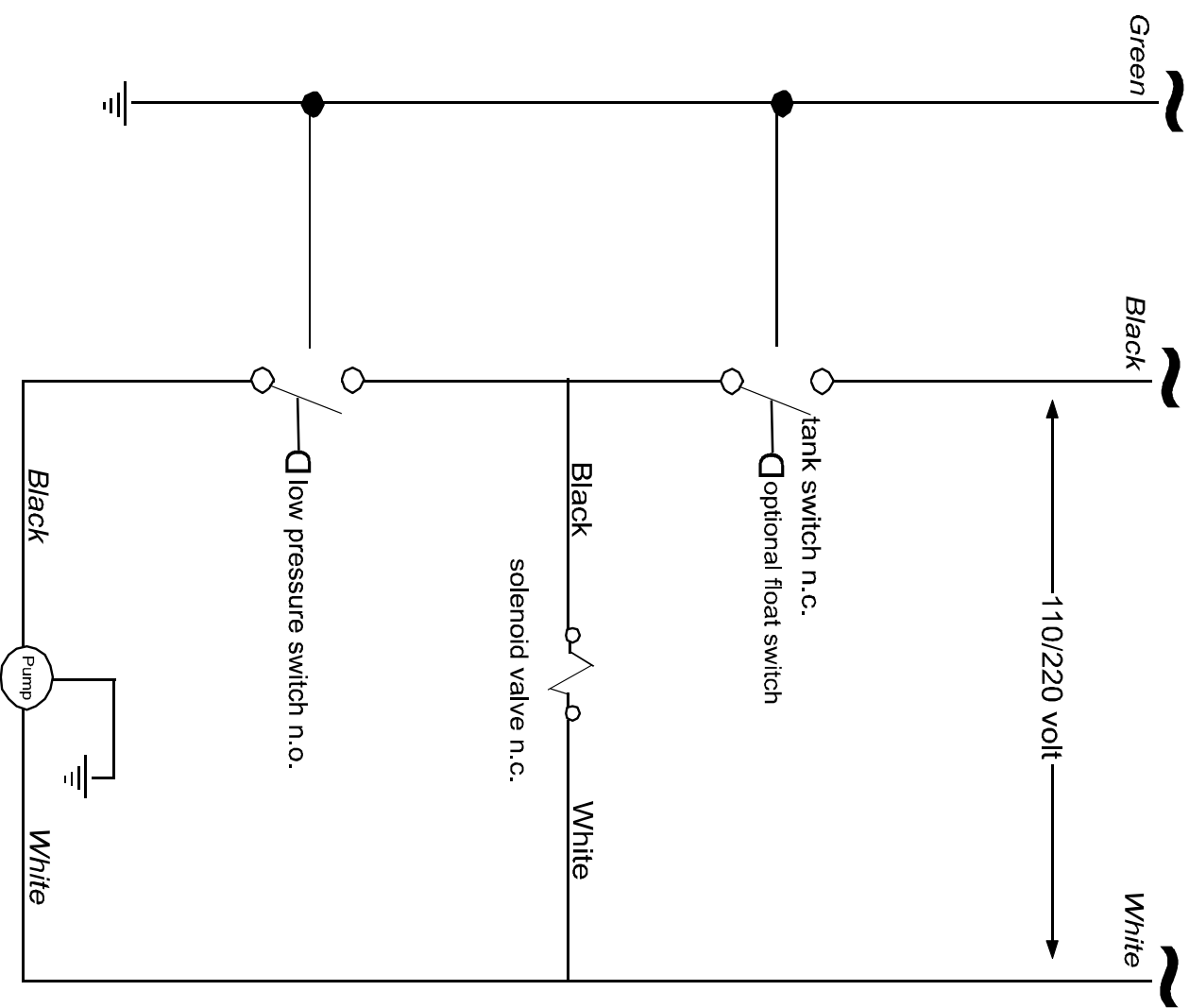

ITEMIZATION OF COMPONENTS

(refer to front and back view image of system)

- 1) **LOW INLET WATER PRESSURE SWITCH:** This switch registers the amount of inlet water pressure supplied to the R. O. pump. If the inlet pressure is too low, (below 10 psi) the pump will not start. This is a protection feature to extend pump life. This switch is rated for 30 amps.
- 2) **JUNCTION BOX WITH ELECTRICAL REQUIREMENTS AND RATING:** A label is affixed to the junction box identifying voltage requirements. There should be no reason for removing this cover, unless any of the electrical components on this R. O. System is to be replaced.
- 3) **PRESSURIZED STORAGE TANK PRESSURE SWITCH:** This pressure switch is standard and is necessary for pressurized storage tanks. It will allow the R. O. System to fill the pressurized storage tank until 45 - 50 psi is sensed by the switch and shuts off the R. O. System. This switch is rated for 30 amps.
- 4) **PRE-FILTER IN GAUGE:** This gauge measures the water pressure before the pre-filter. When there is a drop 10 - 15 psi difference of pressure readings between the pre-filter in and pre-filter out gauges, the pre-filters are getting clogged and must be changed. This gauge will register a reading at all times.
- 5) **PRE-FILTER OUT GAUGE:** This gauge measures the water pressure after the pre-filter. When there is a drop 10 - 15 psi difference of pressure readings between the two gauges, the pre-filters are getting clogged and must be changed. This gauge will register a reading only while system is running.
- 6) **PRODUCT OUTLET CONNECTION:** This is where the product water comes out of the membrane. This water must be connected to the pure water storage tank. A plastic compression fitting is at this location that has a 3/8" OD dimension. **MUST USE 3/8" POLYETHYLENE TUBING.** Failure to use polyethylene can result in possible leaks.
- 7) **WASTE OUTLET CONNECTION:** There must be water flowing across the membrane at all times during operation. There is a portion of water that is "de-salted"; what's left behind is a concentrate. This concentrate must be directed to the drain at a fixed flow rate set by factory. A plastic 3/8" compression fitting will make the connection to drain. **MUST USE 3/8" POLYETHYLENE TUBING.** Failure to use polyethylene can result in possible leaks.
- 8) **10" 5 MICRON PRE-FILTER AND HOUSING:** The sediment pre-filter (rated at 5 micron) removes the dirt particles to 5 micron and larger. This filter helps extend membrane life.
- 9) **10" CARBON BLOCK PRE-FILTER AND HOUSING:** The carbon block filter is used before the membrane to remove the chlorine from the inlet water. TFC membranes used on this system are chlorine sensitive. Care must be taken to ensure that all chlorine is removed from the water supply. It is suggested that a ½ cu.ft. carbon filter is used on 800 gpd R. O. Systems to limit the frequency of carbon pre-filter change-outs.
- 10) **INLET SOLENOID VALVE:** The inlet solenoid valve provides positive water flow shut-off when the R. O. system is not in operation.

11) R. O. MEMBRANE AND HOUSING: The Thin Film Composite membrane removes up to 99%+ of the suspended solids. The membrane housing contains the R. O. membrane.

12) SYSTEM PRESSURE GAUGE: This gauge is liquid-filled with a range of 0-300 psi. It will register the pressure of water applied to the input of the membrane. This gauge will register a reading only when system is running.

13) MOTOR: The motor turns the pump at 1725 rpm at a 60hz electrical supply and 1425 rpm at 50hz electrical supply. On 50hz electrical supplies, the operating pressure will be lower than 200 psi because the motor turns slower than the pump output specifications require.

14) PRESSURE RELIEF ADJUSTING SCREW: The pressure relief adjustment will increase or decrease the operating pressure of the pump. Adjustments with the relief valve should only be used when pump output flow decreases due to carbon impeller wear over time.

15) SINGLE-STAGE ROTARY VANE PUMP: The pressure pump increases the inlet pressure and flow to the membrane. The increased pressure must not be more than 200 psi maximum. The pump is constructed of brass with carbon impellers.

COMPONENTS NOT VISIBLE ON IMAGE:

INLET WATER CONNECTION: The feed water connection is made at the inlet of the sediment pre-filter. The fitting is to be supplied by the installer. Connection sizes 3/8" FPT or 1/2" FPT.

AUTOMATIC FLUSHING SOLENOID VALVE (optional): This is an optional feature to the R. O. System. Once an hour for two minutes, only during system operation, this valve opens. The drain flow is dramatically increased at this time. This increased flow rate helps remove any particles clogged into the membrane.

ELECTRICAL CORD: (110v comes with plug, 220v without plug): The electrical cord is provided for connection to a power supply

TROUBLE SHOOTING GUIDE

SYSTEM NOT STARTING	<ol style="list-style-type: none">1) Check power supply to system2) Inlet solenoid non-functional3) Pre-filter clogged4) Low pressure switch defective5) Not enough water pressure (must be at least 15 psi)6) Defective motor7) Product pressure switch non-functional
SYSTEM NOT TURNING OFF WHEN TANK IS FULL	<ol style="list-style-type: none">1) Defective product pressure switch
SYSTEM CYCLING ON AND OFF	<ol style="list-style-type: none">1) Clogged pre-filters2) Malfunctioning low pressure switch3) Defective product check valve
SYSTEM NOT UP TO FULL PRESSURE (175-195 psi)	<ol style="list-style-type: none">1) Defective pump2) Defective flow control
FOUL TASTE OF PRODUCT WATER	<ol style="list-style-type: none">1) Defective membrane2) Check carbon post-filter

Date Manual last updated: February 10, 2004