



Avant™ Series

Operation and Maintenance

User Manual

Original Instructions

Edition 5

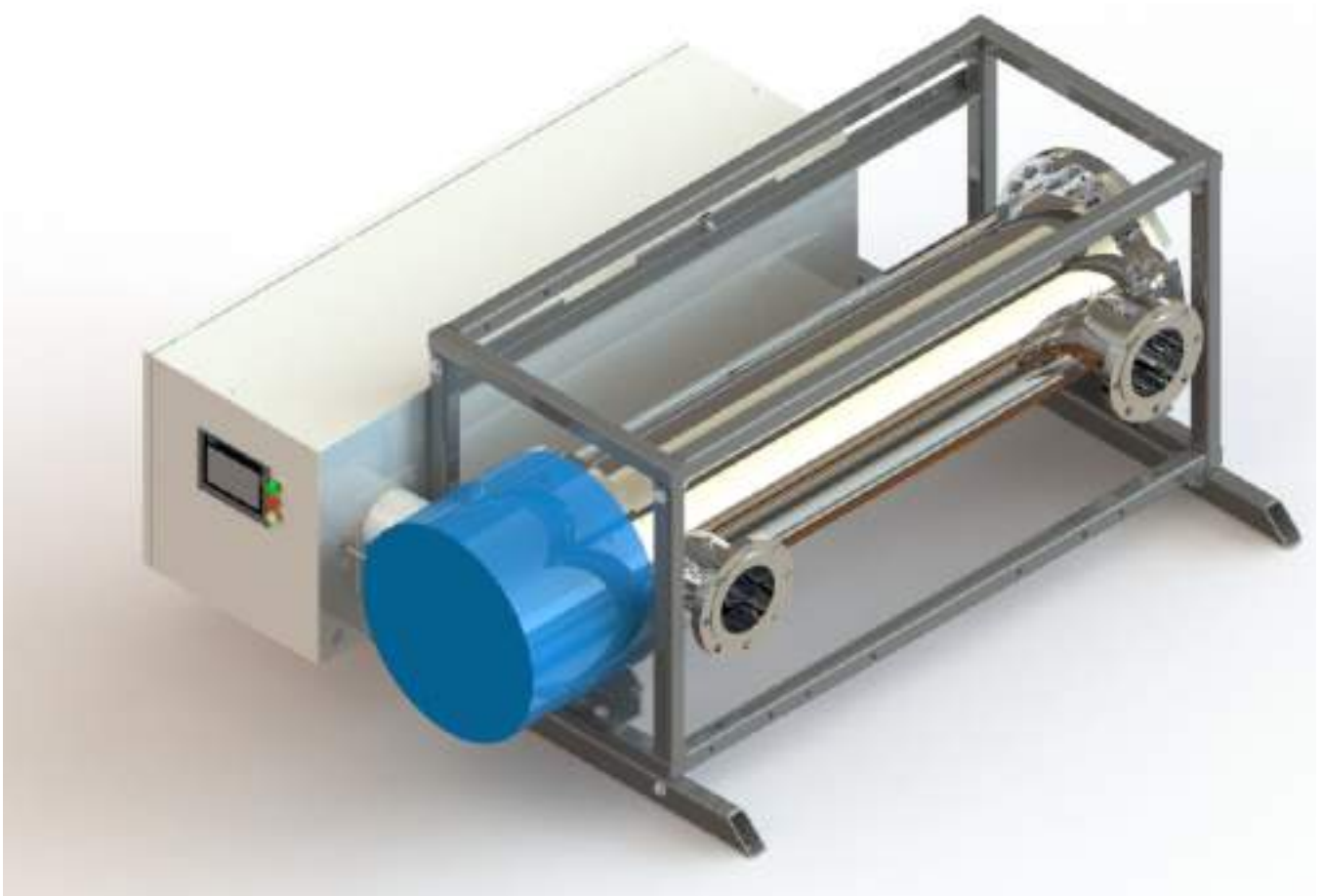

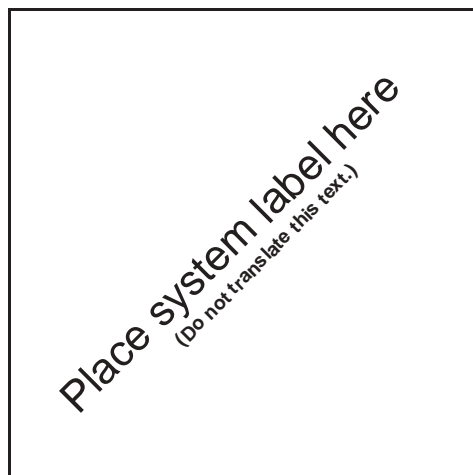

If you require technical assistance, please contact Aquafine Corporation Technical Support using the contact information below:

Telephone: 1-661-257-4770
E-mail: techservice@trojantechnologies.com

At the time of publishing, the information within this document is current. Due to continuous improvements, we may have future changes and recommendations which will be sent via product bulletins.

Section 1 Specifications	7
Section 2 Safety Information	9
2.1 Use of Hazard Information	9
2.2 Precautionary Labels	9
2.3 Safety Precautions	11
2.4 Safety Features.....	14
Section 3 General Information	15
3.1 Acceptable Noise Levels.....	15
3.2 Patents and Permissions	15
3.3 Abbreviations and Acronyms	15
3.4 System Overview	16
3.4.1 UV Chamber	17
3.4.2 Control Power Panel	18
3.4.3 Sample Ports.....	18
3.4.4 UVI Sensor (Optional).....	18
Section 4 Lockout Tag Out	19
4.1 Lockout Tag Out Procedure.....	19
4.1.1 Equipment Shutdown	19
4.1.2 Deactivate Energy Sources.....	19
4.1.3 Lockout Tag Out Energy Sources	20
4.1.4 Verify the Lockout	20
4.2 Remove the Lockout Tag Out	20
Section 5 System Startup and Shutdown	21
5.1 Start-Up Procedure	21
5.1.1 Pre-Start Checklist:	21
5.2 Shutdown Procedure.....	22
5.2.1 UV Unit.....	22
Section 6 Shipment and Storage	23
6.1 Shipping Contents.....	23
6.2 How the equipment is shipped.....	23
6.3 Storage requirements before the install	23
6.4 Overview of Equipment Connections	23
Section 7 Installation	25
7.1 Tools and Materials.....	25
7.2 Pre-Installation	25
7.3 UV Chamber	26
7.3.1 Install UV Chamber without a Skid.....	26
7.3.2 Install UV Chamber with Low Profile Skid Base.....	28
7.3.3 Install UV Chamber with High Profile Skid Base.....	31
7.3.4 Install a Stacked UV Chamber	36
7.3.5 Connect Inlet and Outlet Process Piping to the UV Chamber (ANSI Flanges).....	38
7.3.6 Connect Inlet and Outlet Process Piping to the UV Chamber (Sanitary Fitting)	38
7.4 Control Power Panel	39
7.4.1 Electrical Connections.....	40
7.5 Assemble the UVI Sensor	44
7.6 Hydrostatic Test	45
Section 8 Operation	47
8.1 User Interface.....	47
8.1.1 Color Codes and Icons.....	47
8.1.2 Alarm and Warning Color Codes	48
8.1.3 User Interface Navigation Bar	48
8.1.4 Login Screen	49

Table of Contents

8.2 System Overview Screen	50
8.2.1 System Status Information	51
8.2.2 Control Mode Screen.....	51
8.2.3 Local System Control Buttons	53
8.2.4 Remote Control Mode Message.....	53
8.3 Lamp Status Screen.....	53
8.3.1 Lamp and Driver Information Screen.....	54
8.3.2 Lamp and Lamp Driver Information	55
8.3.3 Reset a Lamp Driver Fault.....	55
8.3.4 Reset Lamp Hours.....	55
8.4 Settings Screen	57
8.4.1 Set 100% Relative UVI	58
8.4.2 TOC Signal Settings.....	59
8.5 Active Alarms Screen	59
8.5.1 Alarm History Screen.....	60
8.6 Information Screen	60
8.6.1 Date and Time Screen.....	61
8.6.2 Diagnostic Overview Screen	61
Section 9 Maintenance.....	63
9.1 Tools and Materials	63
9.2 Maintenance Schedule.....	64
9.3 Depressurize and Drain a UV Chamber	65
9.4 Pressurize the UV Chamber.....	66
9.5 Remove and Install the Service End Cap.....	67
9.6 UV Lamp	68
9.6.1 Storage Requirements for Used UV Lamps	68
9.6.2 Remove and Replace a UV Lamp	68
9.7 UVI Sensor.....	71
9.7.1 Remove and Replace a UVI Sensor - TOC.....	71
9.7.2 Remove and Replace a UVI Sensor - Liquid Sugar	73
9.8 Lamp and UVI Sensor Sleeve	77
9.8.1 Remove and Replace a Sleeve.....	77
9.8.2 Clean a Sleeve	81
9.9 UV Chamber End Plate	82
9.9.1 Remove and Install the UV Chamber End Plate	82
9.9.2 Remove and Replace End Plate O-Ring.....	86
9.10 Baffle Assembly.....	87
9.10.1 Remove and Replace a Baffle Assembly	87
9.10.2 Remove and Replace a Sleeve Bushing.....	88
9.10.3 Remove and Replace a Baffle Plate Guide O-Ring.....	89
9.11 Control Power Panel	90
9.11.1 Remove and Replace a Lamp Driver	90
9.11.2 Air Filters	94
9.11.3 Cooling Fan	94
9.12 Clean the UV Chamber	94
9.13 Clean in Place (CIP).....	94
Section 10 Troubleshooting	95
10.1 Alarms	95
10.2 Alarm Conditions	96
10.3 Non Alarm Conditions	98
10.3.1 UV Chamber.....	98
10.3.2 UV Lamp.....	99
10.3.3 Lamp Socket.....	99
10.3.4 UVI Sensor	100

10.3.5 Control Power Panel	100
Section 11 Replacement Parts and Accessories	101
11.1 UV Lamp and Lamp Sleeve	101
11.2 UVI Sensor.....	102
11.3 Systems without UVI Sensor.....	103
11.4 UVI Sensor.....	104
11.5 Baffle Assembly	105
11.6 UV Chamber	106
11.6.1 Port Plugs - Flanged Connections - TOC Applications	107
11.6.2 Port Plugs - Sanitary Ferrule Connections - Liquid Sugar Applications	108
11.7 Control Power Panel	109
11.8 Miscellaneous	109

Section 1 Specifications

Specifications are subject to change without notice.

General				
Fluid Standard Temperature Range	40°F to 104°F (4°C to 40°C)			
Fluid High Temperature Range (Liquid Sugar Applications only)	40°F to 131°F (4°C to 55°C)			
Ambient Air Temperature	35°F to 95°F (2°C to 35°C)			
Ambient Storage Temperature	-4°F to 104°F (-20°C to 40°C)			
Ambient Relative Humidity	10% to 90%, non-condensing			
Control Power Panel (Skid Mounted)				
Enclosure Rating	UL Type 1 (IP51)			
Material	Painted Carbon Steel			
Dimensions H x W x D in. (cm)	22 x 64 x 21 (56 x 163 x 53)			
Cooling Mechanism	Forced Air and Vent			
Supply Voltage	Refer to Component Label			
Control Power Panel (Standalone)				
Enclosure Rating	UL Type 12 - IP54 (Standard), UL Type 4X - IP55 with fan (Optional)			
Material	Painted Mild Steel Standard (304 Stainless Steel Optional)			
Dimensions H x W x D in. (cm)	65 x 35 x 19 (166 x 90 x 50)			
Cooling Mechanism	Forced Air and Vent			
Supply Voltage	Refer to Component Label			
UV Chamber				
	Model			
Operating Pressure (Maximum)	AVT20 / AVT20-HP	AVT36 / AVT36-HP	AVT44 / AVT44-HP	AVT48 / AVT48-HP
	150 psi (10 bar)			
Material	316L Stainless Steel			
Number of UV Lamps	20	36	44	48
Weight - 1 Stack, no Skid lbs (kgs)	758 (344)	966 (438)	1086 (493)	1234 (560)
Weight - 1 Stack, with Skid lbs (kgs)	1022 (464)	1230 (558)	1350 (612)	1498 (679)
Weight - 2 Stack, with Skid lbs (kgs)	1918 (870)	2334 (1059)	2574 (1168)	2870 (1302)
Weight - 3 Stack, with Skid lbs (kgs)	2814 (1276)	3438 (1559)	3798 (1723)	4242 (1924)
Inlet / Outlet Diameter Size (ANSI)	4"	6"	6"	8"
Maximum Flow Rate* - Standard Quartz	80 - 250 gpm (352.2 - 1100.8 m ³ /hr)			
Maximum Flow Rate* - High Performance Quartz	Contact Aquafine for Sizing			
<i>*Flow Rate at 99% UVT</i>				
UV Lamp				
Type	Low pressure, High output (254 nm or 185 nm, with non-validated or validated options)			
Lamp Sleeve Material	Natural Quartz (Synthetic Quartz Optional)			
Lamp Driver				
Input	207-277 VAC, 50-60Hz			

Specifications

UVI Sensor	
Output range	4 to 20 mA current loop (2 wire)
Supply Voltage	24 VDC from the Control Power Panel
Maximum Operational Temperature	131°F (55°C)
Maximum Non Operational Temperature	194°F (90°C)
System Regulatory Compliance	
cULus, CE, UKCA and KC optional	

Section 2 Safety Information

Please read this entire manual before operating this equipment. Pay attention to all danger, warning and caution statements in this manual. Failure to do so could result in serious personal injury or damage to the equipment.







Make sure that the protection provided by this equipment is not impaired. Do not use or install this equipment in any manner other than that specified in installation manual.

2.1 Use of Hazard Information















⚠ DANGER
Indicates a potentially or imminently hazardous situation which, if not avoided, will result in death or serious injury.
⚠ WARNING
Indicates a potentially or imminently hazardous situation which, if not avoided, could result in death or serious injury.
⚠ CAUTION
Indicates a potentially hazardous situation which, if not avoided, could result in minor or moderate injury.
NOTICE
Indicates a situation that is not related to personal injury.



2.2 Precautionary Labels

Read all labels and tags attached to the instrument. Personal injury or damage to the instrument could occur if not observed.

	<p>Electrical equipment marked with this symbol may not be disposed of in European public disposal systems. In conformity with European local and national regulations (EU Directive 2002/96/EC), European electrical equipment users must now return old or end-of life equipment to the Producer for disposal at no charge to the user.</p> <p>Note: For recycling, please contact the equipment producer or supplier for instructions on how to return end-of-life equipment, producer-supplied electrical accessories, and all auxiliary items for proper disposal. No equipment is to be returned without authorization. Local recycling programs may be used. For the manufacturer recycling UV Lamp program or producer-supplied electrical accessories and auxiliary items, contact the equipment supplier for proper disposal instructions.</p>
	This symbol indicates there is Mercury present.
	This is the safety alert symbol. Obey all safety messages that follow this symbol to avoid potential injury. When on the equipment, refer to the Operational and Maintenance manual for additional safety information.
	This symbol indicates a risk of electrical shock and/or electrocution exists.
	This symbol indicates the marked item has stored energy. Obey procedures to wait 5 (five) minutes after disconnecting main power, to allow stored energy to dissipate.
	This symbol indicates the marked equipment may contain a component that can eject forcibly. Obey all procedures to safely depressurize.
	This symbol indicates corrosive material. Avoid inhalation, ingestion, or exposure to eyes and skin. Wear appropriate clothing and personal protective equipment.



Safety Information

	This symbol indicates the components of the system have been exposed to biohazardous waste.
	This symbol indicates a trained and competent lift operator should be used to move the equipment.
	This symbol indicates a body crush hazard. People should stay clear from under overhead loads.
	This symbol indicates surfaces may be slippery and there is a potential fall hazard.
	This symbol indicates there is a potential UV hazard. Proper protection must be worn.
	This symbol indicates the marked item could be hot and should not be touched without care.
	This symbol indicates that there is a potential ozone exposure hazard. Adequate ventilation is required.
	This symbol indicates that there is potential for VERY hot fluid to drain from UV Chamber openings. Allow fluid inside UV Chamber to cool before performing maintenance or service procedures.
	This symbol indicates that there is potential for VERY hot fluid spray from UV Chamber openings. Obey all procedures to safely depressurize. Allow fluid inside UV Chamber to cool before performing maintenance or service procedures.
	This symbol indicates the marked item should not be touched.
	This symbol indicates a risk of electrical shock and/or electrocution exists. All appropriate lockout tag out procedures must be obeyed.
	This symbol indicates to secure the device with a safety device / hook.
 <small>UV-C</small>	This symbol indicates a safety glasses with side protection is required for protection against UV exposure.
 <small>UV-C</small>	This symbol indicates a UV rated full face shield is required. Face shields are to be worn with safety glasses or safety goggles.
	This symbol indicates gloves must be worn.



	This symbol indicates safety boots must be worn.
	This symbol indicates a hard hat must be worn.
	This symbol indicates the operator must read all available documentation to perform required procedures.

2.3 Safety Precautions

Read the safety precautions in this section before doing maintenance, service or repair. Obey the instructions in the safety precautions. Failure to follow the instructions in the safety precautions can result in serious injury or death.

⚠ DANGER	
	Arc Flash and Shock Hazard - Live Electrical Circuit Present. Hazardous Voltage.
	<ul style="list-style-type: none"> • Failure to follow these instructions will result in electrical shock, injury or death from electrocution. • Devices inside this equipment contain stored energy.
	<ul style="list-style-type: none"> • NEVER work inside this equipment until at least 5 (five) minutes after disconnecting main power to allow stored energy to dissipate. • Lockout tag out all sources of power before performing any inspection, repair, or maintenance. <i>There may be more than one source of power!</i>

⚠ DANGER	
	Shock Hazard.
	<ul style="list-style-type: none"> • Failure to use manufacturer approved parts, including UV Lamps, may result in significant thermal damage to insulation systems which may result in the exposure of live parts.

⚠ DANGER	
	Pressurized Device - Impalement Hazard.
	<ul style="list-style-type: none"> • Failure to follow these instructions will result in serious injury or death due to forcible ejection of materials from UV Chamber. • ALWAYS follow lockout tag out procedures. • NEVER perform any physical inspection, repair, maintenance or service on UV Chamber unless UV Chamber has been isolated, depressurized and open to atmosphere. • NEVER pressurize UV Chamber without service end cap properly installed. • NEVER stand in front of UV Lamp section while UV Chamber is undergoing a hydrostatic pressure test. Stand to the side of the UV Chamber while looking for leaks. • <i>If a leak is observed, depressurize immediately, drain, repair and retest.</i>

⚠ DANGER



Inhalation Hazard.

- Failure to follow these instructions will result in exposure to ozone.
- ALWAYS ensure adequate ventilation.

⚠ WARNING



Personal Injury Hazard.

- Use of parts not approved by the manufacturer may cause personal injury, damage to the UV system or malfunction of the UV System and may void the manufacturer's warranty.
- Use of UV Lamps and Lamp Drivers, not approved by the manufacturer, will void UL and CE product safety certifications.
- The parts listed in [Section 11](#) are approved by the manufacturer.

⚠ WARNING



Body Crush Hazard.

- Failure to follow these instructions could result in serious injury or death due to improper lifting procedures, underrated lifting equipment, and moving parts.
- ALWAYS secure with safety device.
- ALWAYS stay clear of elevated loads.
- ALWAYS comply with local safety regulations.

⚠ WARNING



Scald or Burn Hazard.

- Failure to follow these instructions could result in serious scalds or burns due to exposure to VERY hot fluid.
- Fluid inside UV Chamber may be very hot. Avoid severe burns.
- NEVER touch hot fluid.
- Allow fluid inside UV Chamber to cool before performing maintenance or service procedures.

⚠ CAUTION



UV Light Hazard.

- Failure to follow these instructions may result in serious burns to unprotected eyes and skin.
- ALWAYS use UV protective gear, including gloves and clothing and face shield, when UV light is present.
- NEVER look directly at illuminated UV Lamp, even with protective gear.
- NEVER illuminate UV Lamp if personnel may be directly exposed to UV light.

⚠ CAUTION



Burn Hazard.

- Failure to follow these instructions may result in minor or moderate injury due to burns.
- NEVER touch hot surface.
- Allow UV Lamps to cool for a minimum of 10 (ten) minutes before handling.
- If accidental exposure occurs, immediately cool affected area. Consult physician.



⚠ CAUTION



Slip and Fall Hazard.

- Failure to follow these instructions may result in injuries from a slip and fall.
- ALWAYS ensure safe footing.
- ALWAYS clean up spills promptly.
- ALWAYS comply with site specific safety protocols and procedures.

NOTICE



Mercury Chemical.

- UV Lamps contain a small amount of mercury in either elemental or bound amalgam state, depending on lamp type. These lamps are similar to fluorescent and compact fluorescent lamps (CFL). Always comply with local regulations governing the disposal of lamps containing mercury and the waste associated with breakage.
- NEVER use a vacuum cleaner to clean up broken lamps containing mercury. Vacuuming could spread mercury-containing powder or vapour.
- Thoroughly collect broken glass and trace amounts of mercury and place into a sealable bag or container. For further reference see the U.S. EPA guidelines <http://www.epa.gov/cfl/cleaning-broken-cfl>.
- If you have further questions about the safe clean-up of mercury containing lamps, contact the Aquafine service support group at techservice@trojantechnologies.com

NOTICE



Personal Protective Equipment Required.

- ALWAYS use appropriate eye, hand, and foot protection.
- ALWAYS wear UV-C safety glasses when around equipment or a UV-C faceshield with safety glasses or safety goggles when inspecting open running equipment.
- ALWAYS follow plant safety procedures and protocols.
- ALWAYS take all necessary precautions when working around, operating, or working on this equipment, if contamination of components is expected within this application due to effluent biological or chemical contaminants.

NOTICE



Only competent personnel should undertake operation, repairs, maintenance, or servicing of equipment described in this manual. Maintain the continuity of the lockout tag out between shifts. If you do not understand the information or procedure explanations in this manual, STOP and contact your Service Provider for assistance.

Safety Information

NOTICE

The **Aquafine Avant** breaks down trace levels of ozone, chlorine and total organic carbon.

The **Aquafine Avant LS** system inactivates Alicyclobacillus, Salmonella and Escherichia coli (E. coli).

NOTICE

The product has only the approvals listed and the registrations, certificates and declarations officially provided with the product. The usage of this product in an application for which it is not permitted is not approved by the manufacturer.



WARNING: This product can expose you to chemicals including phthalates, which is known to the State of California to cause cancer, and mercury, which is known to the State of California to cause birth defects or other reproductive harm. For more information go to www.P65Warnings.ca.gov.

Notes: 1) *Dispose of contaminated parts/components as per country requirements.*

2) *Refer to the Safety Data Sheets for accidental exposure to materials.*

2.4 Safety Features

The UV System has safety features that prevent personal injury:

- Service End Cap - The electrical power supplied to all lamp holders is turned off when the service end cap is removed.
- Door disconnect switch - A disconnect switch removes power to the UV System.

Section 3 General Information

The information in this manual has been carefully checked and is believed to be accurate. However, the manufacturer assumes no responsibility for any inaccuracies that may be contained in this manual. In no event will the manufacturer be liable for direct, indirect, special, incidental or consequential damages resulting from any defect or omission in this manual, even if advised of the possibility of such damages. In the interest of continued product development, the manufacturer reserves the right to make improvements in this manual and the products it describes at any time, without notice or obligation.

3.1 Acceptable Noise Levels

The airborne noise emissions, A-weighted emission sound pressure level, is not more than 70dB(A).

3.2 Patents and Permissions

The products described in this document may be protected by one or more patents in The United States of America, Canada and/or other countries. For a list of patents owned by Trojan Technologies, go to:

www.trojantechnologies.com/patents.

No part of this publication may be reproduced, stored in a retrieval system, or transmitted in any form or by any means without written permission of Aquafine Corporation.

3.3 Abbreviations and Acronyms

Table 1 describes the abbreviations and acronyms included in this manual.

Table 1 Abbreviations and Acronyms

Abbreviation/Acronym	Description
AC	Alternating Current
AO	Analog Output
CE	Conformité Européenne (European Conformity)
CPP	Control Power Panel
cULus	Underwriters Laboratories Listed to Canadian and USA standards
ELCB	Earth Leakage Circuit Breaker
EOL	End of Life
EPDM	Ethylene Propylene Diene Monomer
FKM	Fluorocarbon based fluoroelastomer material
HMI	Human Machine Interface
HP	High Performance
KC	Korea Certification
lbf.ft	Pounds force foot
lbf.in	Pounds force inch
LOA	Lamp Out Alert
LS	Liquid Sugar
N.m	Newton metre
psi	pounds per square inch
TOC	Total Organic Carbon
UKCA	UK Conformity Assessed
UV	Ultraviolet
UVI	Ultraviolet Intensity

3.4 System Overview

The system is a pressurized UV Chamber that uses high-output low pressure UV Lamps.

Figure 1 shows the components for a TOC UV System. These systems have ANSI flange inlet/outlet connections.

Figure 2 shows the components for a Liquid Sugar UV System. These systems have sanitary fitting inlet/outlet connections.

One Control Power Panel (CPP) provides the power distribution for one UV Chamber and controls the UV Chamber through a microprocessor user interface. Refer to Section 8.

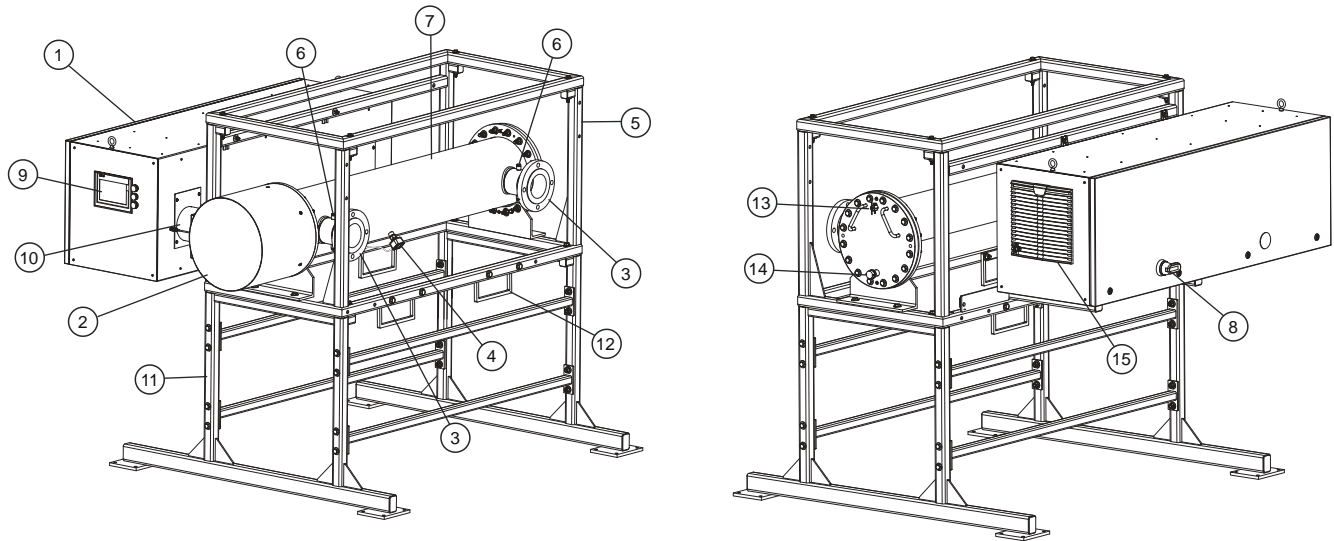

Figure 1 UV System with ANSI Flange Option - 1 UV Chamber Stack, Skidded

1 Control Power Panel (CPP) (Clearance required - Section 7.4)	2 Service End Cap (Clearance required - Section 7.2)
3 Inlet/Outlet Connections	4 UVI Sensor (Optional) (Section 3.4.4)
5 UV Chamber Support Frame (Optional)	6 Sample Port
7 UV Chamber	8 Disconnect Handle
9 Human Machine Interface	10 Wireway
11 Skid Frame Base* (Optional)	12 Fork Lift Slots
13 UV Chamber Vent port	14 Drain Connection
15 CPP Vent	

*High Profile Skid Frame Base shown.

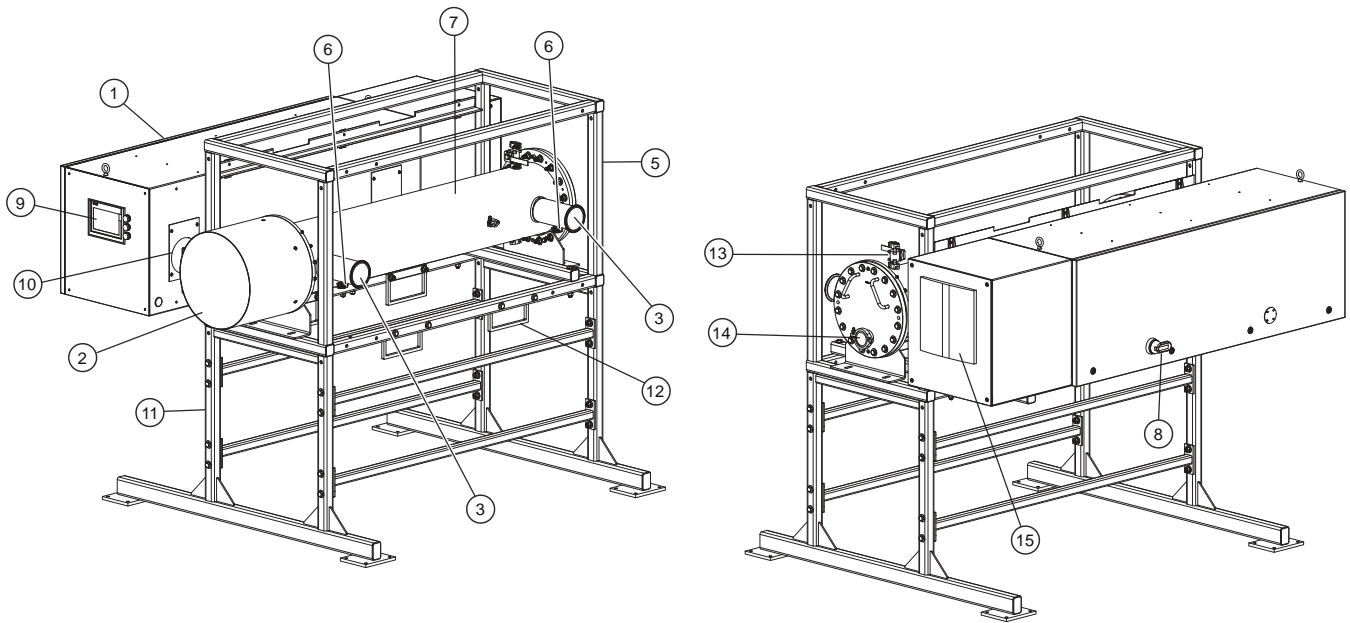

Figure 2 UV System with Sanitary Flange Option - 1 UV Chamber Stack, Skidded

1 Control Power Panel (CPP) (Clearance required - Section 7.4)	2 Service End Cap (Clearance required - Section 7.2)
3 Inlet/Outlet Connections	4 UVI Sensor (end plate mounted, not shown) (Section 3.4.4)
5 UV Chamber Support Frame (Optional)	6 Sample Port
7 UV Chamber	8 Disconnect Handle
9 Human Machine Interface	10 Wireway
11 Skid Frame Base* (Optional)	12 Fork Lift Slots
13 UV Chamber Vent port	14 Drain Connection
15 CPP Vent	

*High Profile Skid Frame Base shown.

3.4.1 UV Chamber

The UV Chamber contains the UV Lamps and Lamp Sleeves.

General Information

3.4.2 Control Power Panel

The CPP contains the Lamp Drivers that power and control the UV Lamps.

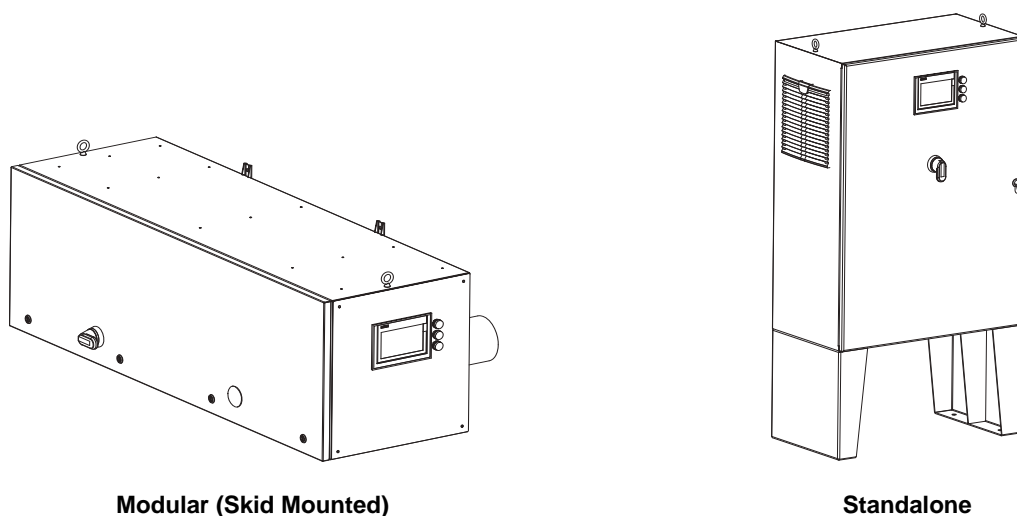

Figure 3 Control Power Panel

3.4.3 Sample Ports

Two optional ports are available for obtaining fluid samples pre-and post UV Chamber.

3.4.4 UVI Sensor (Optional)

The UVI Sensor measures UV Lamp Intensity.

Section 4 Lockout Tag Out

⚠ DANGER



Obey all warning and caution statements. Refer to [Section 2](#).

Read and understand the Operation and Maintenance Manual before operating this equipment. Read all user documentation before performing operations, inspections, repair, or maintenance on this equipment.



Only competent personnel should undertake operation, repairs, maintenance, or servicing of equipment described in this section of the manual. If you do not understand the information or procedure explanations in this manual, STOP and contact your Service Provider for assistance.

The procedure in [Section 4.1](#) is the minimum lockout requirement. Use additional precautions, as needed. Obey all site-specific protocols.

4.1 Lockout Tag Out Procedure

4.1.1 Equipment Shutdown





Contact the plant manager or shift supervisor for help regarding equipment location and identification.

1. Ensure that no hazards will be created by equipment shutdown.
2. Shut down all equipment that will need lockout tag out.
3. Ensure that all moving parts come to a complete stop.

4.1.2 Deactivate Energy Sources

A hazardous energy source is any energy source that can cause serious personal injury or death. The potential hazardous energy sources in this manual are:

1. Identify and deactivate the main isolating device of each energy source:

-  Electrical Energy (Incoming Power)
-  Fluid Pressure (Potential Energy)
-  Thermal (Thermal Energy)
-  UV Light (Radiation Energy)
-  Mechanical (Kinetic Energy)

2.  Disconnect all electrical equipment from power:
 - Disconnect all electrical equipment
 - Power off and disconnect electrical power to hard-wired equipment

3.  Dissipate stored electrical energy in capacitors.
4. Close all shut-off valves.

Lockout Tag Out

4.1.3 Lockout Tag Out Energy Sources



1. Use a multi-lock scissor adaptor to lockout each energy source.
2. Attach a completed lockout tag. Include the required information:
 - Person and company applying the lockout
 - Reason for the lockout
 - Date of the lockout
3. Apply a personal lock.

4.1.4 Verify the Lockout



1. Ensure that the meter is working correctly with a test before and after measuring the de-energized source:
 - a. Test the voltmeter to a known, energized 24 VAC/120 VAC source.
 - b. Use the same voltmeter to test the locked-out energy sources to verify that there is no voltage.
 - c. Test the voltmeter again to a known, energized 24 VAC/120 VAC source.
2. Ensure that the stored energy sources have dissipated.
3. Try to start the de-energized equipment and verify that it does not start.

4.2 Remove the Lockout Tag Out

When the work is finished and the system has been restored to full operational condition, including closing all enclosure doors, the lockout tag out can be removed.

1. Ensure that no hazards will be created by removal of the lockout.
2. Obey manufacturer's instructions and safe work procedures to energize and start the equipment.

Section 5 System Startup and Shutdown

⚠ DANGER



Obey all warning and caution statements. Refer to [Section 2](#).

Read and understand this manual before operating this equipment. Read all user documentation before performing operations, inspections, repair, or maintenance on this equipment.



Only competent personnel should undertake operation, repairs, maintenance, or servicing of equipment described in this section of the manual. If you do not understand the information or procedure explanations in this manual, STOP and contact your Service Provider for assistance.

NOTICE

Do not operate the UV System until the UV Chamber is completely filled with process fluid.

To prevent alarm conditions, overheating or equipment damage, process fluid level and flow in the UV Chamber must be established and maintained at all times when UV Lamps are in operation. Follow all provided site-specific instructions about automatic or manual power to operate the system.

5.1 Start-Up Procedure

5.1.1 Pre-Start Checklist:

1. UV Chamber should be filled with process fluid to be treated. The flow of fluid for the initial filing should not exceed 50 GPM (3.15 L/s). Failure to comply may result in Lamp Sleeve breakage. Ensure there are no system leaks and no piping connection leaks.
2. Check for complete assembly:
 - UV Chamber is fully assembled.
 - Make sure that drainage and by-pass provisions are ready.
 - UV Lamps and Lamp Sleeves are fully assembled and installed.
 - **For TOC Systems:** If supplied, installation of UVI Sensor is complete, otherwise port is plugged.
 - **For Liquid Sugar Systems:** If supplied, installation of the UVI Sensor and Sensor Sleeve is complete.
 - There is fluid in the UV Chamber.
 - There are no leaks in the UV Chamber.
 - The Service End Cap is fastened and secure at the end of the UV Chamber
 - Verify all incoming power connections conductors, including the ground conductor, are properly terminated.
 - Verify that the primary over-current protection device and circuit breaker are in the closed position.
 - Turn the main power disconnect switch to the “ON” position. The enclosure fans, Control Power Panel display screens and the Lamp Drivers will be energized.
3. For Local ON/OFF control:
 - At the CPP HMI → Verify mode on 'Settings 1' screen is set to 'LOCAL'. From 'System Overview' screen under 'Lamps Control', press the On/Off control pushbutton to set the system to the desired state. Refer to [Section 8](#).
4. For Remote - Input ON/OFF control:
 - At the CPP HMI → Verify mode on 'Settings 1' screen is set to 'Remote - Input'. These terminals require only a contact closure to operate the remote relay. When the controller is set to “Remote - Input” operation, the closure at these terminals will “START/STOP” the system from a remote location.

System Startup and Shutdown

5. For Remote - SCADA ON/OFF control:

- At the CPP HMI → Verify mode on 'Settings 1' screen is set to 'Remote - SCADA'. The system then requires only a single signal to start/stop the system. Turn on the signal to start the system from a remote plant controller.

Note: Refer to the SCADA signal list in the Controls Philosophy document for signal definitions.

5.2 Shutdown Procedure

5.2.1 UV Unit

1. The Plant:

Stop the process flow through the UV Chamber as per site specific protocols.

2. For Local ON/OFF control:

- At the CPP HMI → Press the On/Off pushbutton under Lamp Control to power off the UV Lamps. Refer to [Section 8](#).

3. For Remote - Input ON/OFF control:

- These terminals require only a contact closure to operate the remote relay. When the controller is set to "Remote - Input" operation, the closure at these terminals will "START/STOP" the system from a remote location.

4. For Remote - SCADA ON/OFF control:

- Turn off the signal to stop the system from a remote plant controller.

Note: Refer to the SCADA signal list in the Controls Philosophy document for signal definitions.

5. At the CPP → Turn the local disconnect switch to the OFF position.

Section 6 Shipment and Storage

6.1 Shipping Contents

The system consists of two major components, the UV Chamber and the Control Power Panel. Some components may be disconnected at the UV Chamber for shipment.

6.2 How the equipment is shipped

The system is delivered to the site by truck. System components are packed in wooden crates labeled with the component name. Other labels identify components which are fragile or breakable and components which must be kept dry.

To prepare for installation, remove only the shipping straps and bolts that secure the panel to the pallet.

6.3 Storage requirements before the install

The manufacturer recommends indoor storage of the system equipment. The equipment should be stored in a dry warehouse. Heating is not necessary during storage. However, before system start up, the equipment must be warmed to greater than 60°F (15°C) for a period of 24 hours.

Storage area conditions:

- Ambient air temperature between -4°F to 104°F (-20°C to 40°C)
- Relative humidity from 10% to 90%, non-condensing
- Free from dust and dirt ingress
- Must not contain corrosive or explosive gases
- Free from salt air
- Vermin free

If indoor storage is not possible, the panel may be stored outdoors, with additional conditions:

- Equipment is stored on high ground that is not susceptible to flooding.
- Equipment is elevated a minimum of 12 inches (300 mm) above the ground or as appropriate to prevent flooding.
- Equipment is completely covered with waterproof tarps to prevent exposure to the elements (e.g., rain, snow, sand, dust etc.). Tarps must be tight fitting, attached securely and examined regularly. Water and snow accumulation should be removed regularly.
- Equipment stored in crates should not be exposed to direct sunlight.
- Equipment can be stored in sea containers.

6.4 Overview of Equipment Connections

Refer to the general layout drawings provided by the manufacturer. If the supplied layout drawings do not match the site conditions, contact the manufacturer for assistance.

Section 7 Installation

⚠ DANGER



Obey all warning and caution statements. Refer to [Section 2](#).









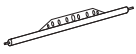

Read and understand this manual before operating this equipment. Read all user documentation before performing operations, inspections, repair, or maintenance on this equipment.

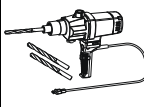

Only competent personnel should undertake operation, repairs, maintenance, or servicing of equipment described in this section of the manual. If you do not understand the information or procedure explanations in this manual, STOP and contact your Service Provider for assistance.

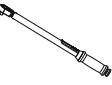
7.1 Tools and Materials

The following is a list of tools needed to install the UV System.

Symbols	Description	Symbols	Description
	Lifting straps (properly sized and rated for equipment load)		Spreader Bar (properly sized and rated for equipment load)
	Drill - Concrete Hammer		Drill with bits
	Level		Tape measure
	Wrench - Socket		Wrench - Adjustable
	Wrench - Torque		Wrench
	Philips Screwdriver		Anti-Seize

All Aquafine products are carefully inspected and tested before shipment from our plant. Upon delivery, check the packaging and equipment for damage that occurred during shipment.

7.2 Pre-Installation

- When preparing the site for installation, allow for valves, drain and bypass as part of your plumbing circuit.
- It is recommended to have a provision to bypass and isolate the UV Chamber from flow, to allow for UV Chamber shutdown for maintenance and/or service purposes.
- Connecting pipes to the UV System should be supported, to avoid any undue strain on the UV Chamber.
Note: *The UV System should not bear any load of the attached piping.*
- For CPP side and front clearance ([Figure 3](#)) refer to local codes for local minimum requirements.
- Allow for sufficient service access around the UV Chamber.

UV Lamp Length	Service Area Clearance (Figure 1)
60 inch	72 inches (1830 mm)

Installation

6. If your piping system is subject to impulse pressure resulting in “water hammer” condition, a surge tank or other means must be provided to remove this condition; otherwise the extreme momentary pressure may rupture and fracture the Lamp Sleeves.
7. Avoid locations that experience vibration within proximity of heavy equipment or from erratic pumps. Excessive vibration from other equipment can cause damage to UV Lamps within the UV Chamber.

7.3 UV Chamber

The UV Chamber may be installed with or without a skid.

Installations without a skid

The UV Chamber is required to be supported by piping supports provided by others ([Section 7.3.1](#)). The Control Power Panel is required to be floor mounted ([Section 7.4](#)).

Installations with a Skid

The UV Chamber and the Control Power Panel are supported by the supplied skid. Skids are capable of stacking one (1), two (2) or three (3) UV Chambers and Control Power Panels high ([Section 7.3.4](#)). The base skid provided may be either Low Profile ([Section 7.3.2](#)) or High Profile ([Section 7.3.3](#)).

All valves, manifold piping and connection piping to be supplied by others.

Note: The UV Chamber and Control Power Panel module will be preassembled onto the skid prior to shipment.

NOTICE

FOR LIQUID SUGAR APPLICATIONS

Good Manufacturing Practice (GMP) requires a thorough cleaning of food contact surfaces. Ensure all wetted surfaces in the UV Chamber are cleaned and sanitized in accordance with the facility standard operating procedures and / or local regulatory requirements.

7.3.1 Install UV Chamber without a Skid

Prerequisites:

- Clear the area where the UV Chamber will be installed.
- Remove UVI Sensor if lifting straps interfere with the UVI Sensor Assembly. Refer to [Section 9.7.1](#) - **applies to TOC systems only.**

Tools:

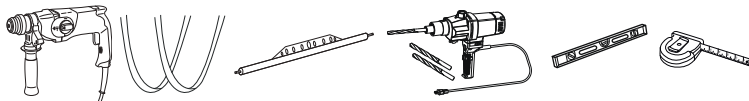

Materials:



- Anchoring hardware (by others)
- Shims, if required (by others)

Procedure:



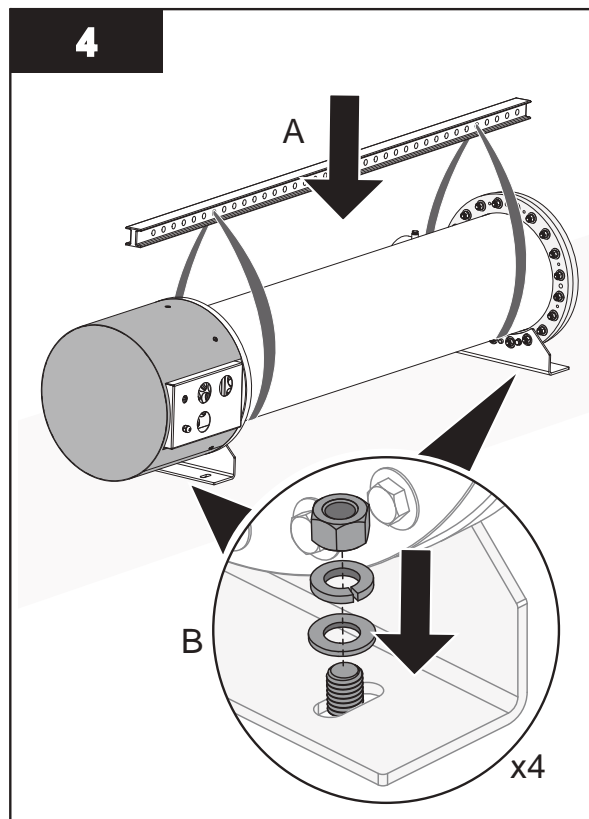
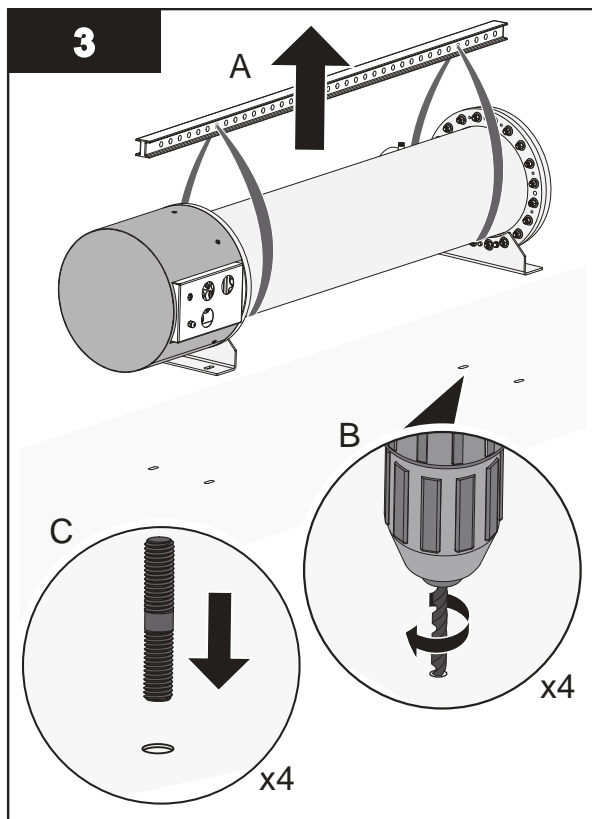
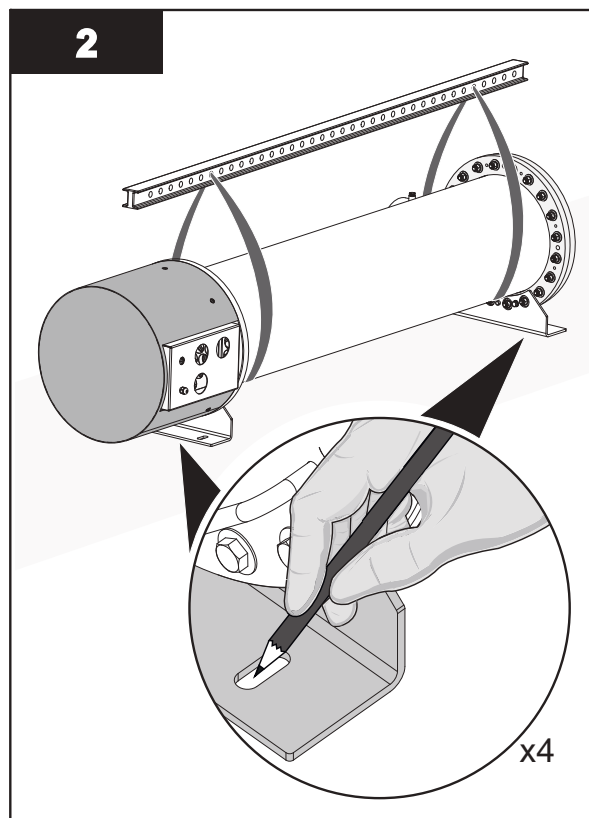
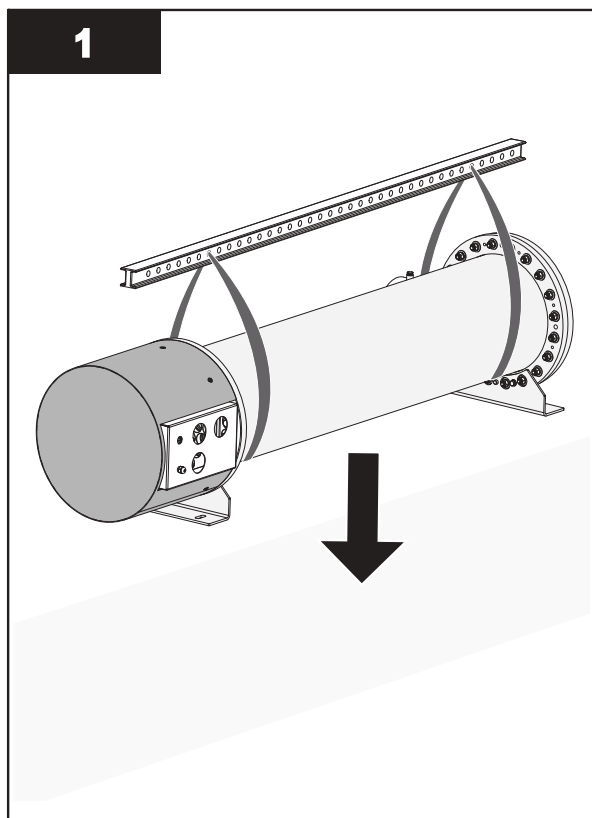

Note: Loosely install the mounting hardware.

5. Level the UV Chamber from side to side and front to back (horizontal).
6. Tighten the mounting hardware.
7. Remove the lifting straps.

Installation

8. Install UVI Sensor, if previously removed. Refer to [Section 9.7.1](#) - *applies to TOC systems only*.
9. Connect UV Chamber Inlet and Outlet to Plant process piping:
 - For UV Chamber with ANSI Flanges, refer to [Section 7.3.5](#).
 - For UV Chamber with Sanitary Flanges, refer to [Section 7.3.6](#).

7.3.2 Install UV Chamber with Low Profile Skid Base

Prerequisites:

- Clear the area where the UV Chamber will be installed

Tools:



Materials:



- Anchoring hardware (by others)
- Skid Mounting and Assembly Hardware (provided)
- Shims, if required (by others)

Procedure:

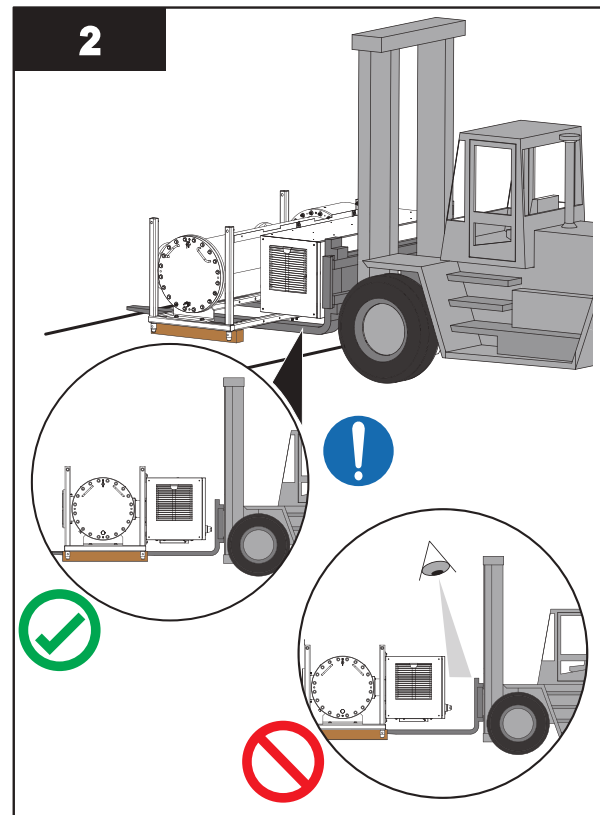
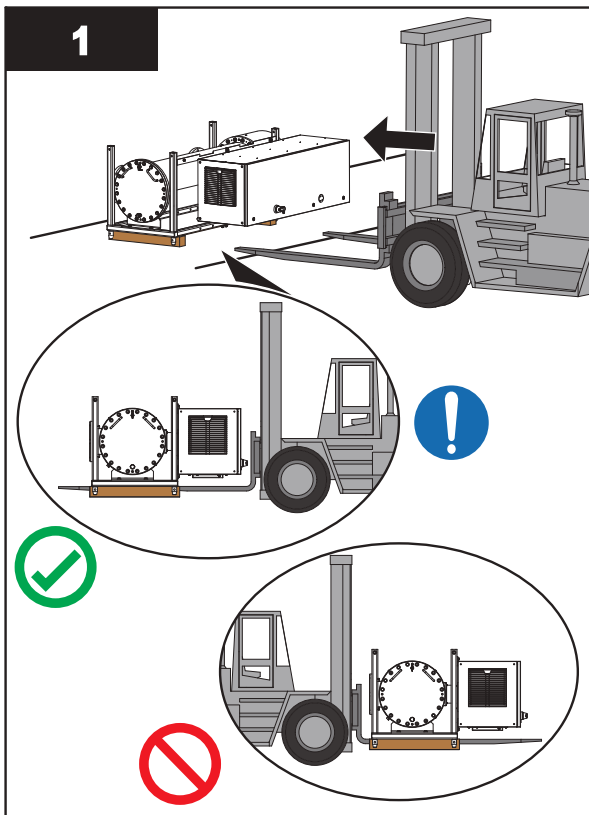

Note: Center the fork lift with the skid to balance the load.

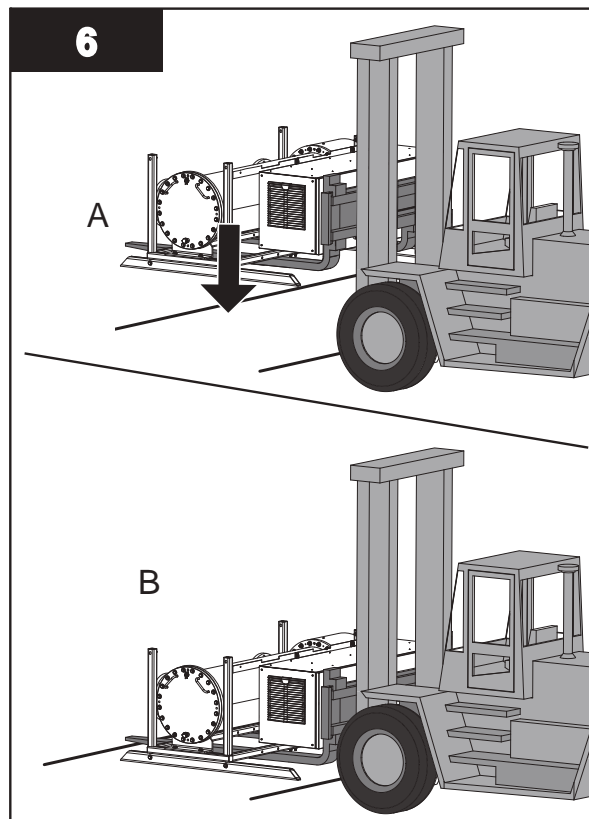
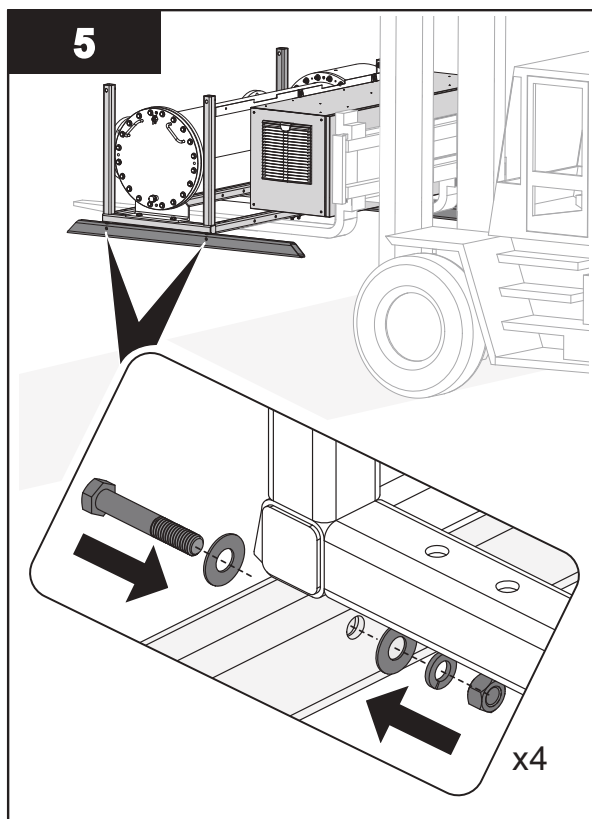
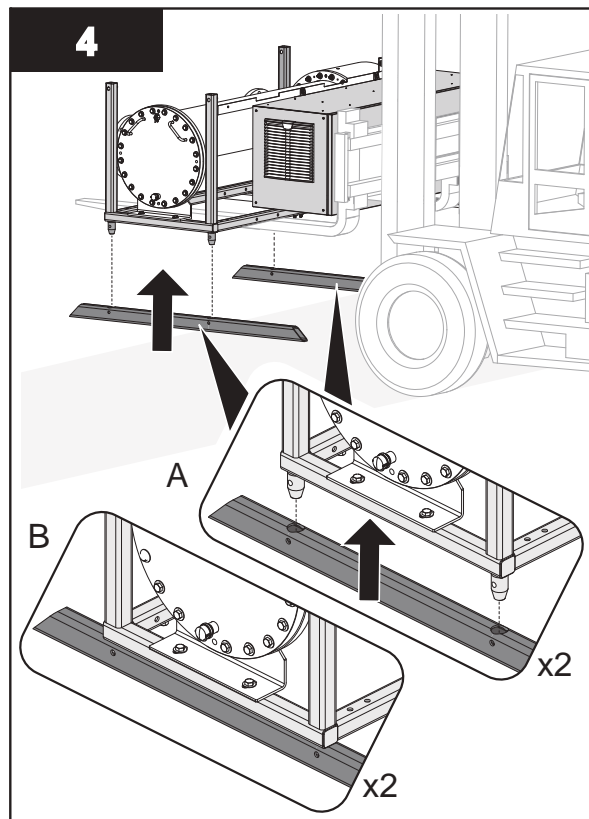
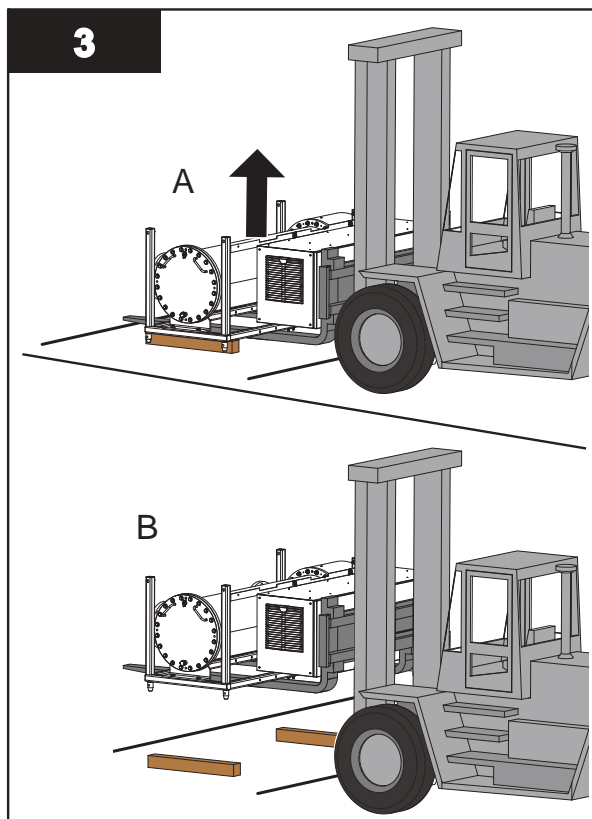

Note: Move UV Chamber Skid to the final installation location.

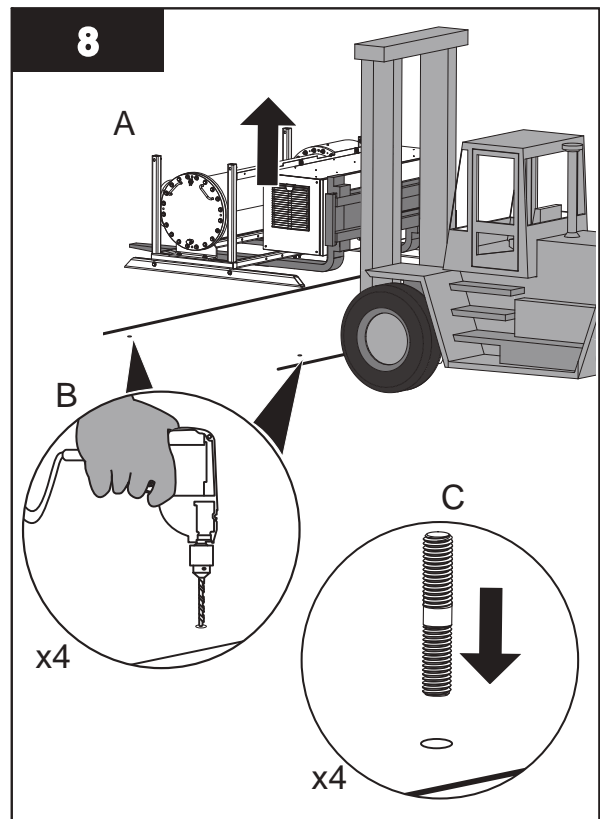
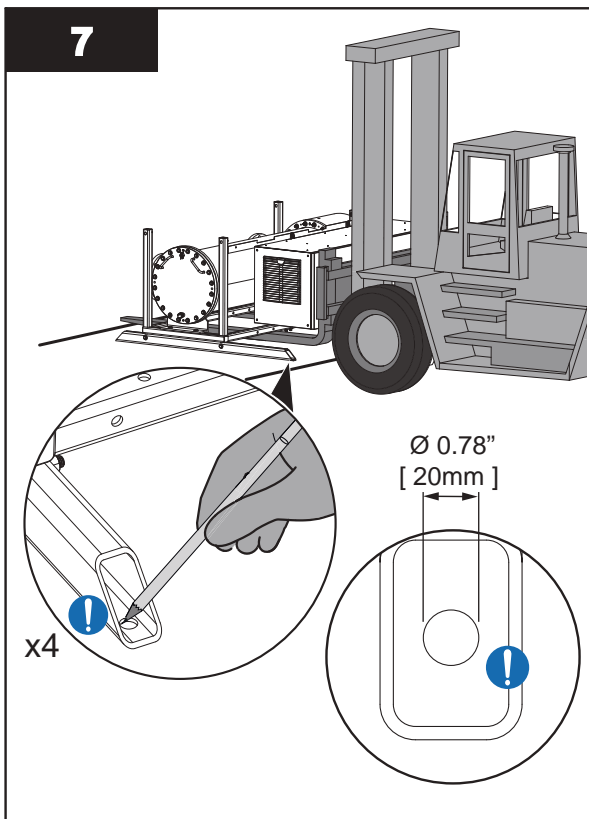

Note: Temporarily move the UV Chamber Skid away from the work area.

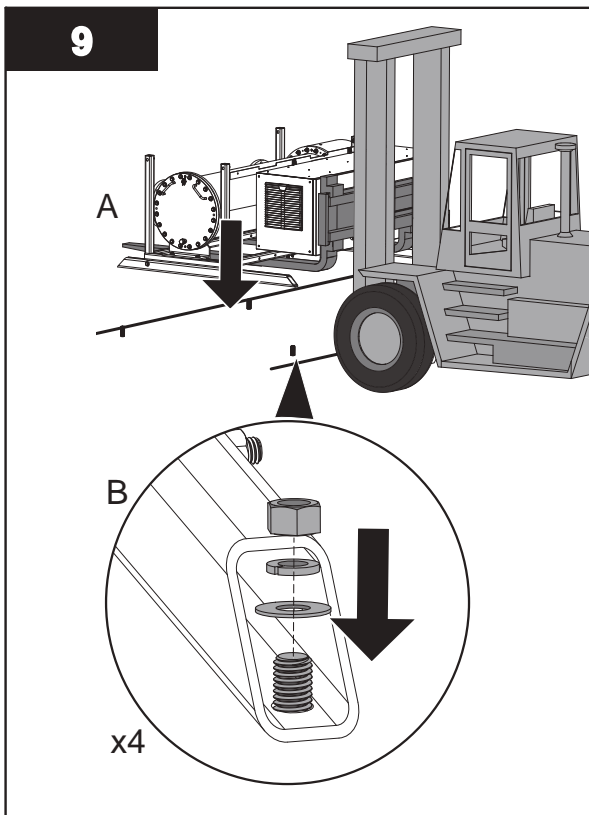

10. If a UV Chamber is required to be stacked onto the base assembly, go to [Section 7.3.4](#) and if not, proceed to Step 11.

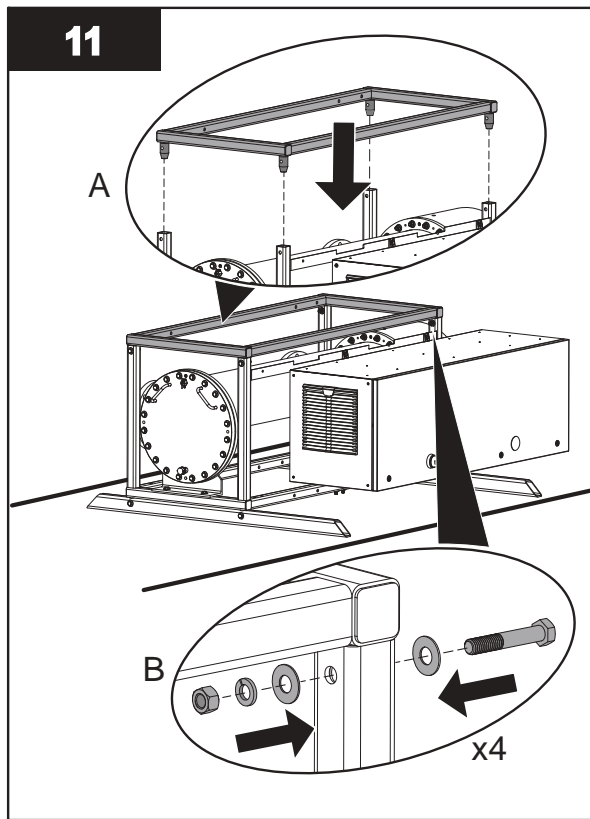

12. Connect UV Chamber Inlet and Outlet to Plant process piping:

- For UV Chamber with ANSI Flanges, refer to [Section 7.3.5](#).
- For UV Chamber with Sanitary Flanges, refer to [Section 7.3.6](#).

7.3.3 Install UV Chamber with High Profile Skid Base

Prerequisites:

- Clear area where the UV Chamber will be installed

Tools:

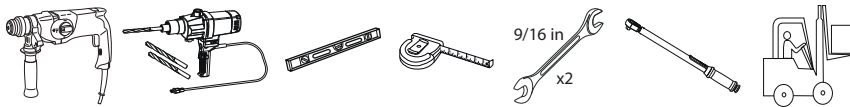

Materials:



- Anchoring hardware (by others)
- Skid Mounting and Assembly Hardware (provided)
- Shims, if required (by others)

Procedure:



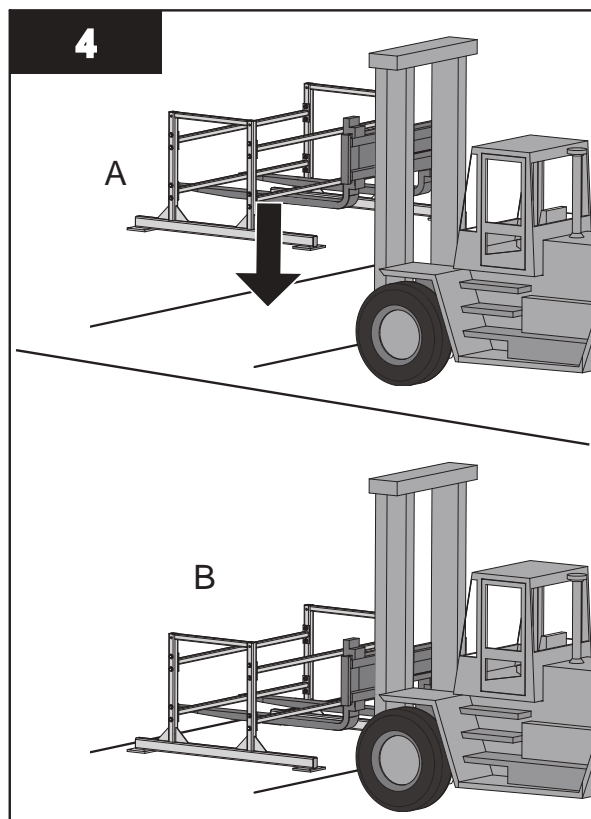
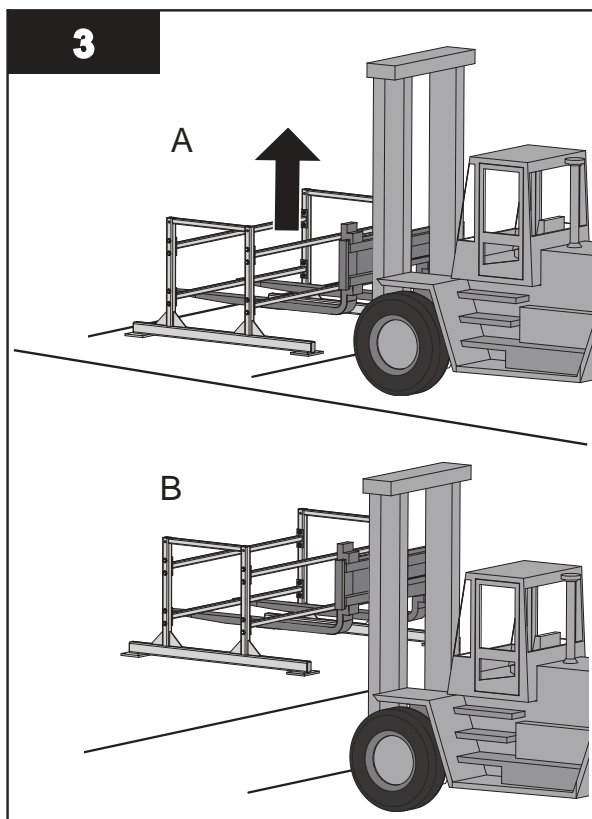
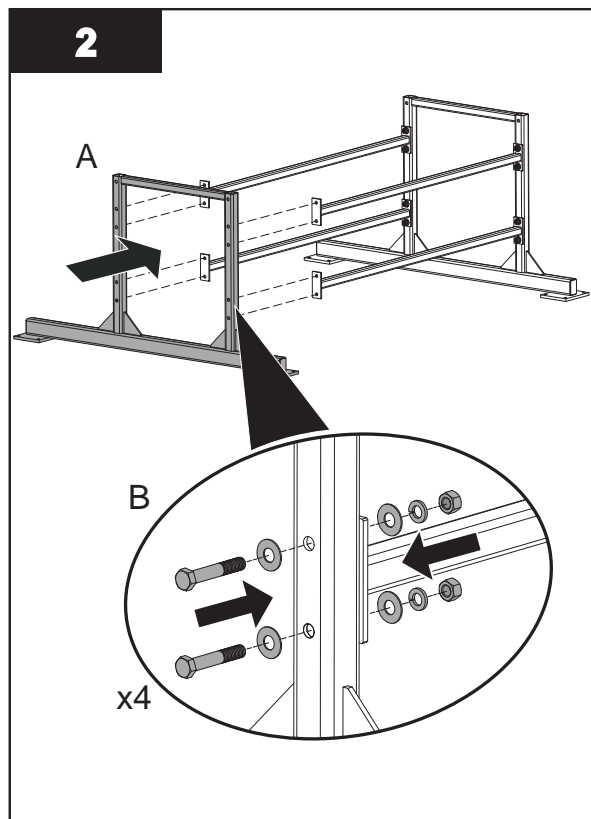
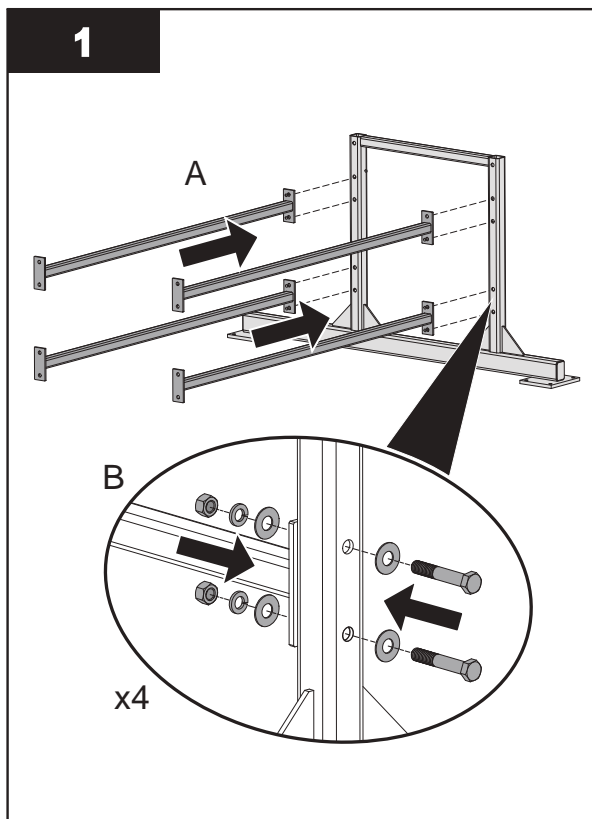

Note: Move the skid to the final installation location.

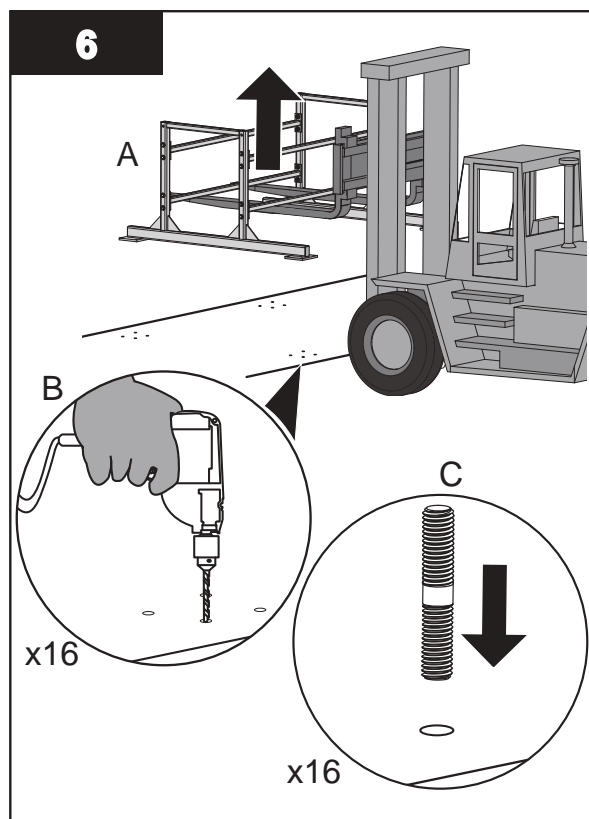
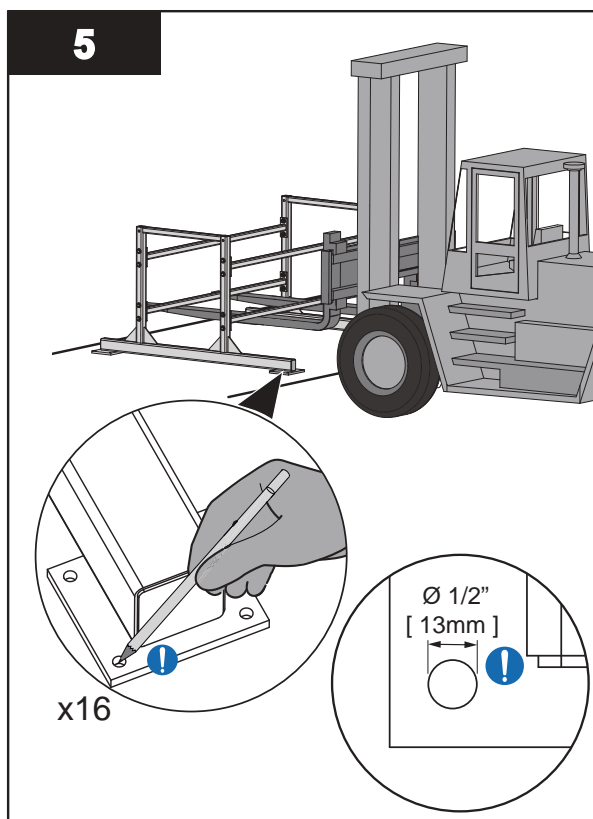

Note: Temporarily move the skid away from the work area.

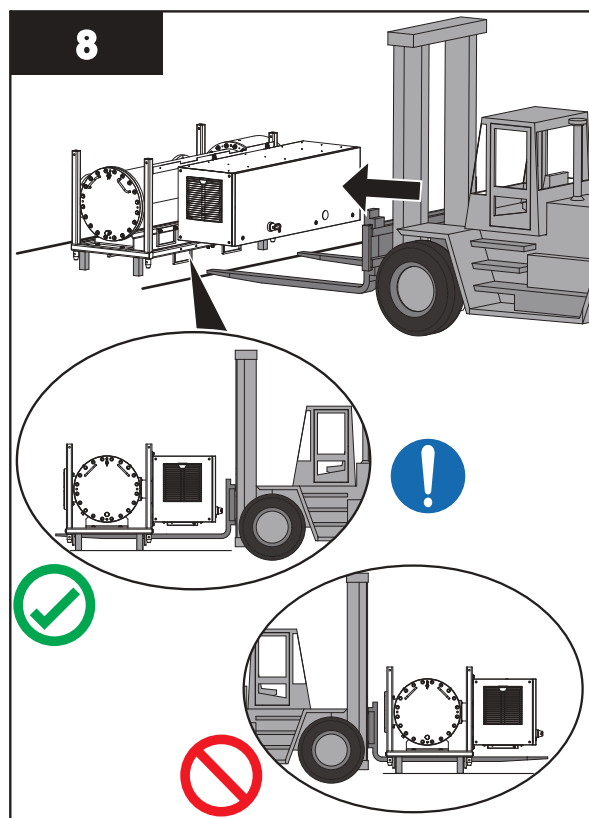
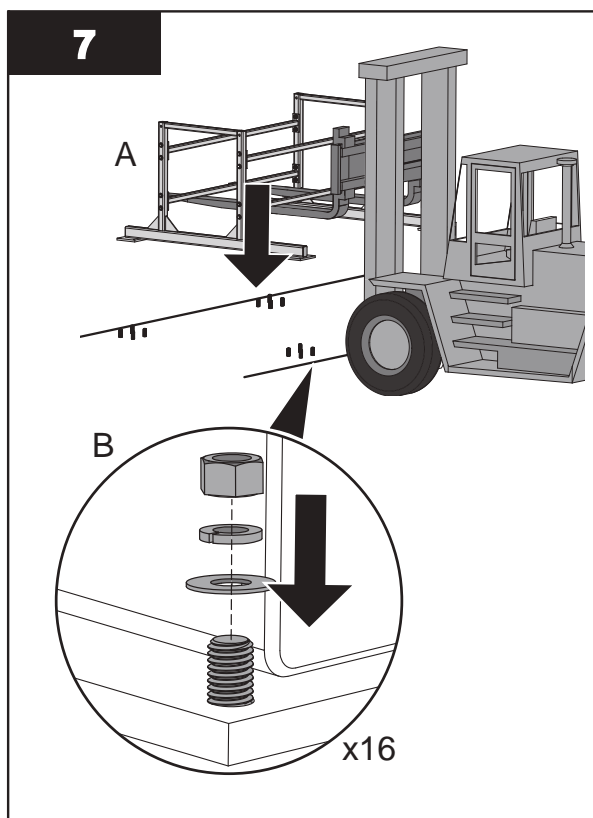

Installation

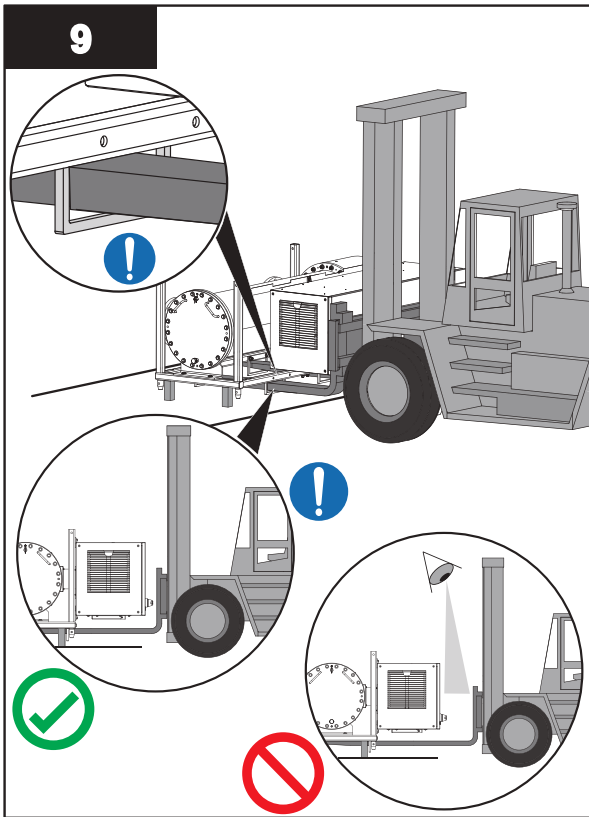

Note: Ensure that the fork tines are fully seated in the slots on the skid assembly.

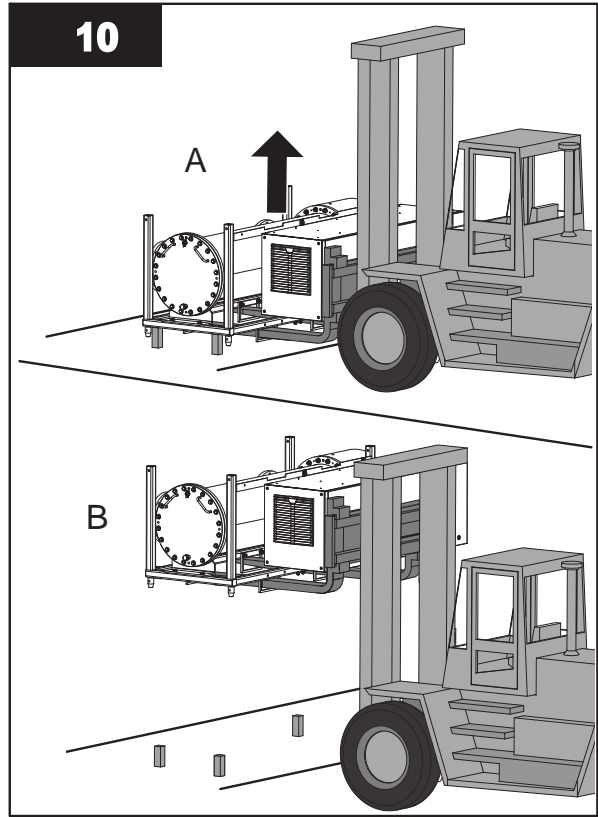

Note: Move UV Chamber Skid to the final installation location.

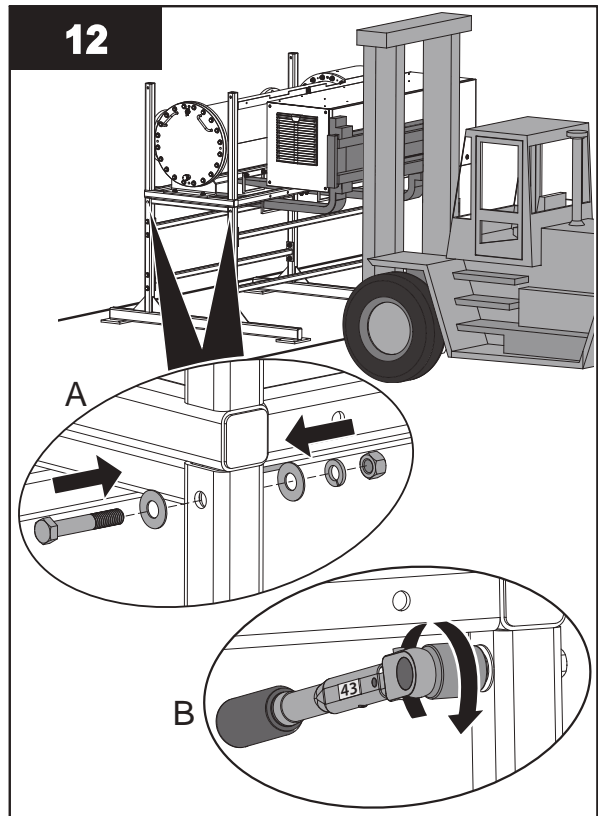
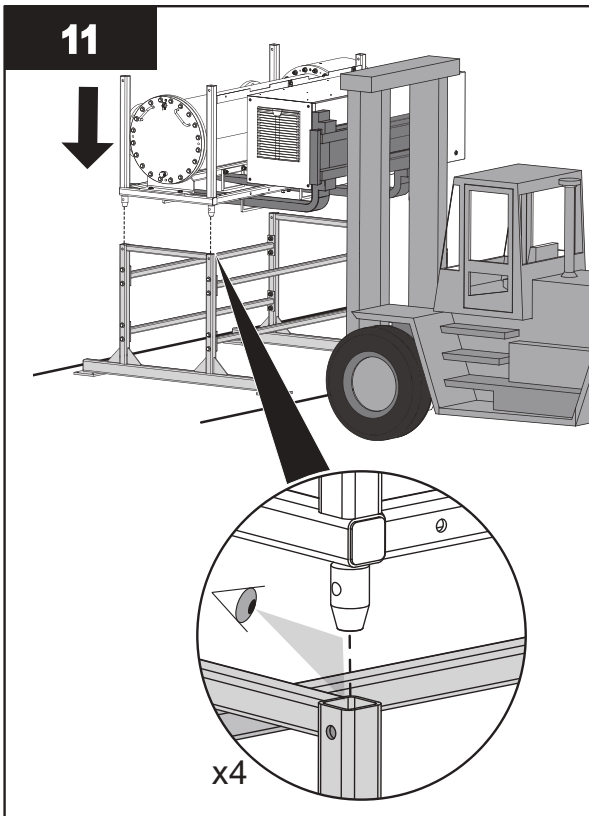

Note: Torque the bolts to 58 N.m (43 lbf.ft).

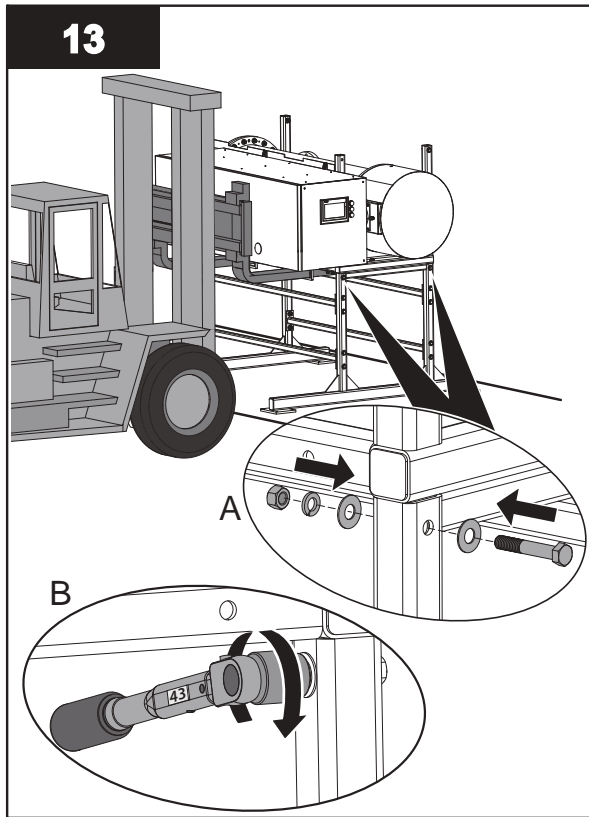

Note: Torque the bolts to 58 N.m (43 lbf.ft).

14. If a UV Chamber is required to be stacked onto the base assembly, go to [Section 7.3.4](#) and if not, proceed to Step 15.

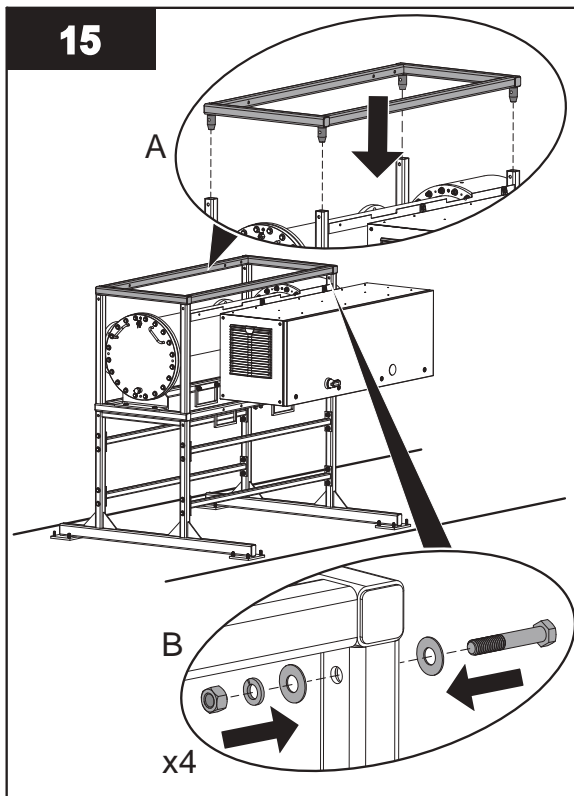

Installation

16. Connect UV Chamber Inlet and Outlet to Plant process piping:

- For UV Chamber with ANSI Flanges, refer to [Section 7.3.5](#).
- For UV Chamber with Sanitary Flanges, refer to [Section 7.3.6](#).

7.3.4 Install a Stacked UV Chamber

Prerequisites:

- Install a UV Chamber with a Low Profile Skid Base. Refer to [Section 7.3.2](#).
OR
- Install a UV Chamber with a High Profile Skid Base. Refer to [Section 7.3.3](#).

Note: The procedure below shows the Stacked UV Chamber installed on a Low Profile Skid Base for illustration purposes, the procedure will be the same for a High Profile Skid Base.

Tools:



Materials:



- Skid Mounting and Assembly Hardware (provided)
- Shims, if required (by others)

Procedure:

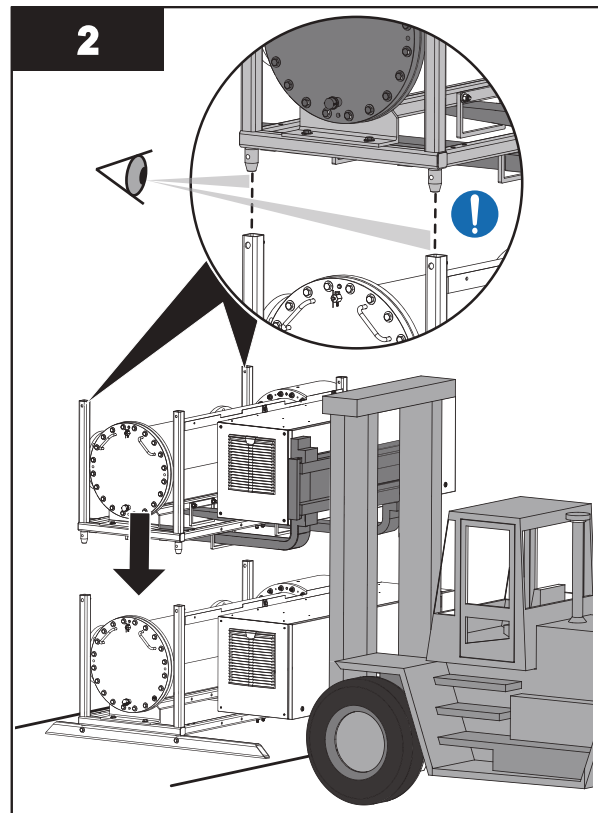
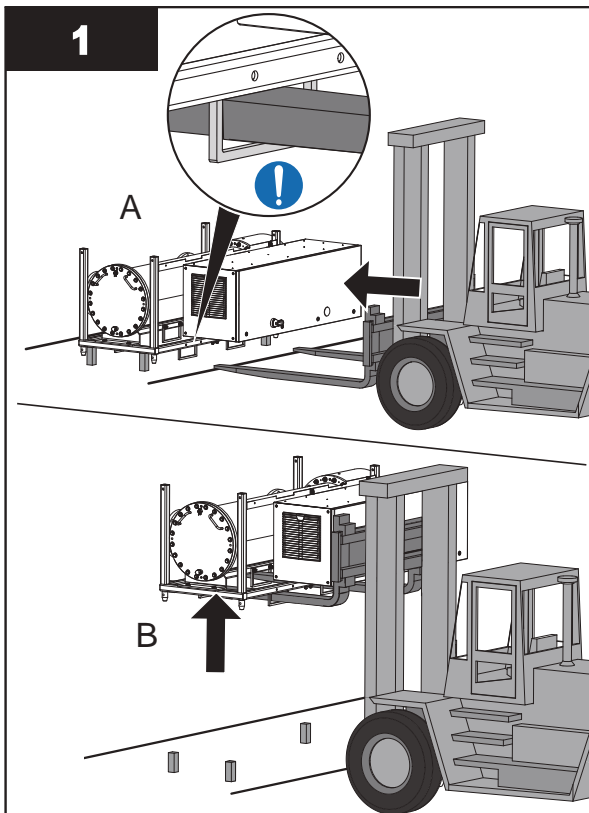

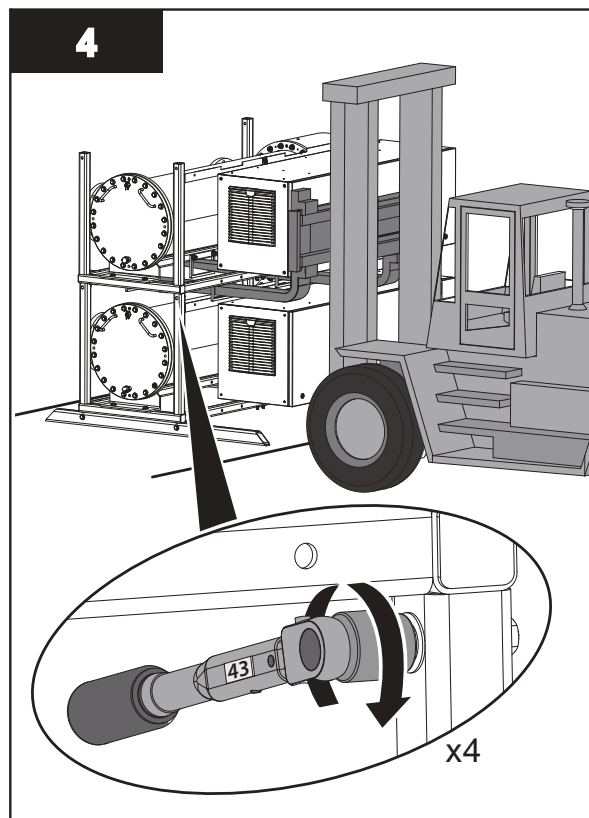
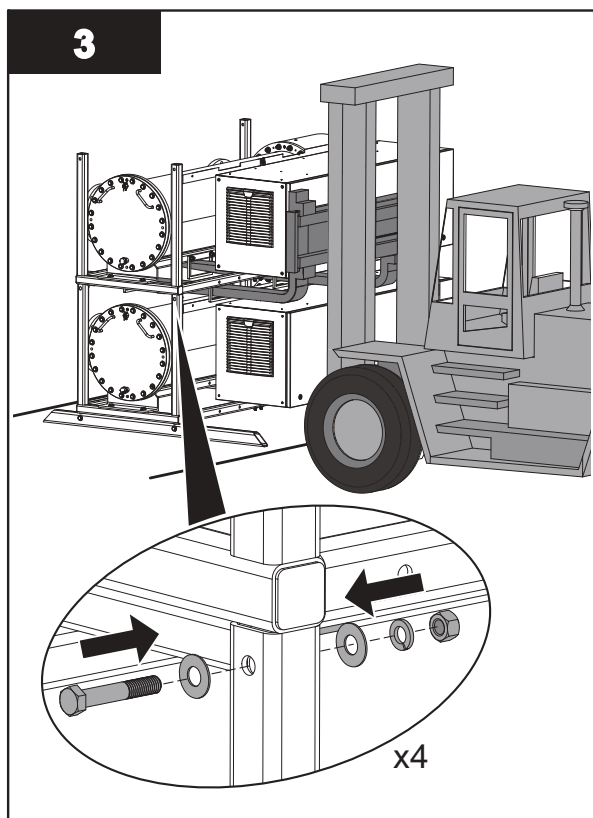

Note: Torque the bolts to 58 N.m (43 lbf.ft).

5. If additional UV Chambers are required to be stacked, repeat steps 1, 2, 3 and 4 in this procedure. If there are no additional stacked UV Chambers to be stacked, proceed to Step 6.

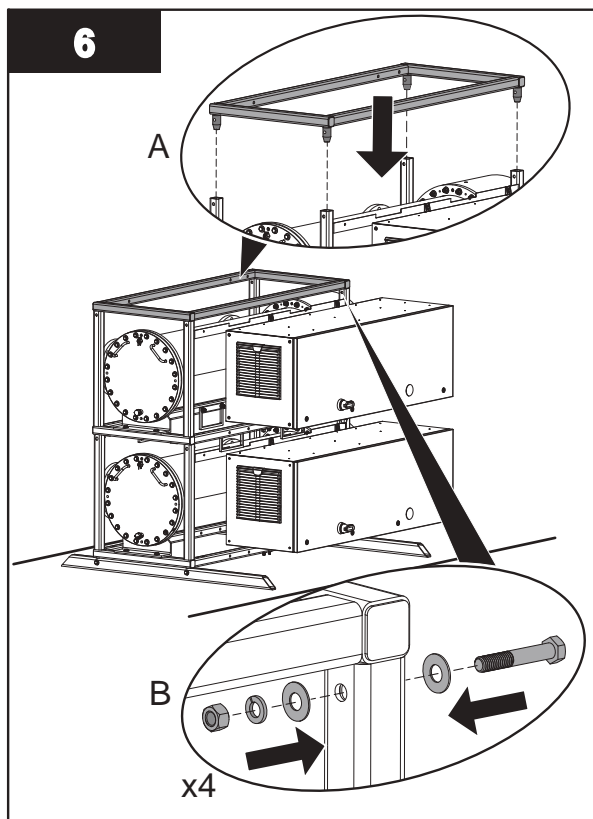

Installation

7. Connect UV Chamber Inlet and Outlet to Plant process piping:

- For UV Chamber with ANSI Flanges, refer to [Section 7.3.5](#).
- For UV Chamber with Sanitary Flanges, refer to [Section 7.3.6](#).

7.3.5 Connect Inlet and Outlet Process Piping to the UV Chamber (ANSI Flanges)

Prerequisites:

- Install the UV Chamber(s).
- Remove the blue Flange Gasket Covers located on the inlet and outlet flanges.
- Clean and inspect inlet and outlet connections for any damage (i.e. scratches, nicks, gouges and burrs)

Tools:

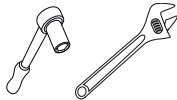

Materials:



- Bolts and hardware (by others)
- Gaskets x 2 (by others)

Procedure:

1. Install gasket on UV Chamber inlet connection.
2. Apply anti-seize lubricant and install bolts.
3. Tighten bolts to bolt manufacturers torque recommendation.
4. Repeats steps 1-3 for the UV Chamber outlet connection.

7.3.6 Connect Inlet and Outlet Process Piping to the UV Chamber (Sanitary Fitting)

Prerequisites:

- Install the UV Chamber(s).
- Clean and inspect inlet and outlet connections for any damage (i.e. scratches, nicks, gouges and burrs)

Tools:

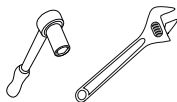

Materials:



- Sanitary Flange Clamps (by others)

Procedure:

1. Loosely install the sanitary clamp on the UV Chamber inlet flange to the plant inlet supply piping.

Note: The UV Chamber will not bear the load of process piping or other equipment. Make sure all piping is properly supported independent of the UV Chamber.

2. Repeat step 1 for the outlet piping.
3. Level the UV Chamber from front to back.

Note: The UV Chamber must be installed such that it remains full of process fluid at all times during operation and must be mounted level to ensure it drains properly when service is required.

4. Secure the sanitary clamp and torque to the manufacturer's specifications.

7.4 Control Power Panel

Note: This procedure only applies to UV Chambers without a skid.

Prerequisites:

- Clear area where CPP will be installed.

Tools:

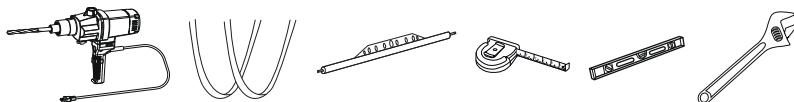

Materials:



- Mounting hardware

Procedure:

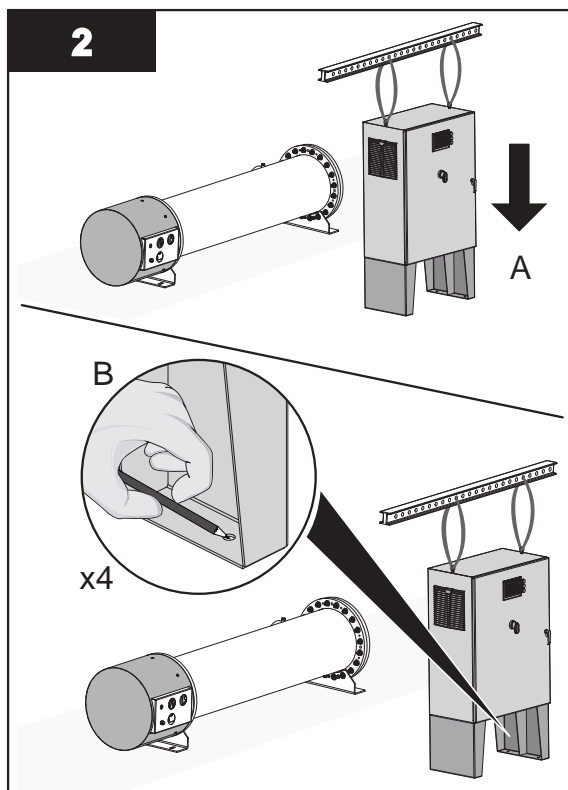
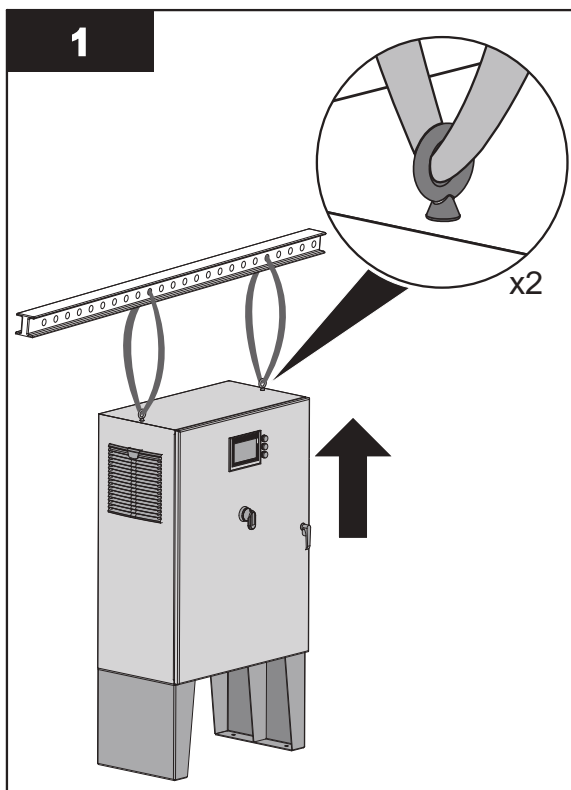

Note: The CPP requires a minimum of 12 inches (305mm) each side of the Control Power Panel to allow for adequate air movement.

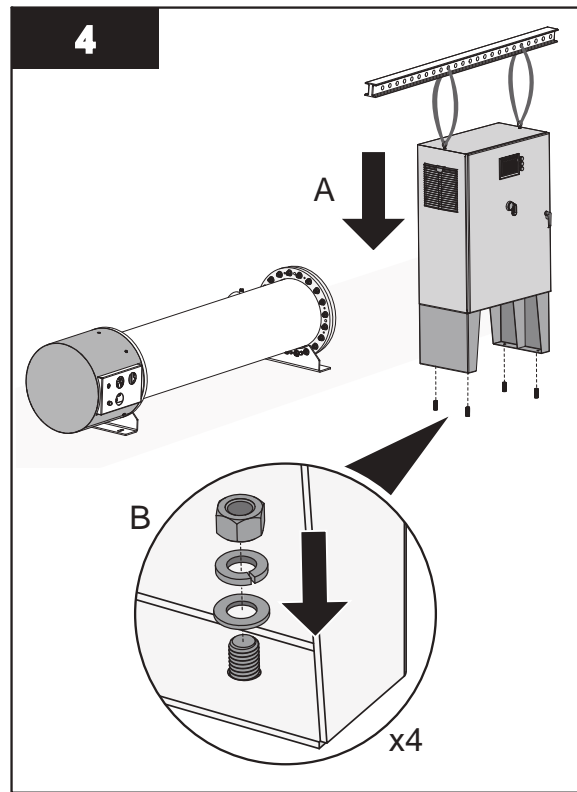
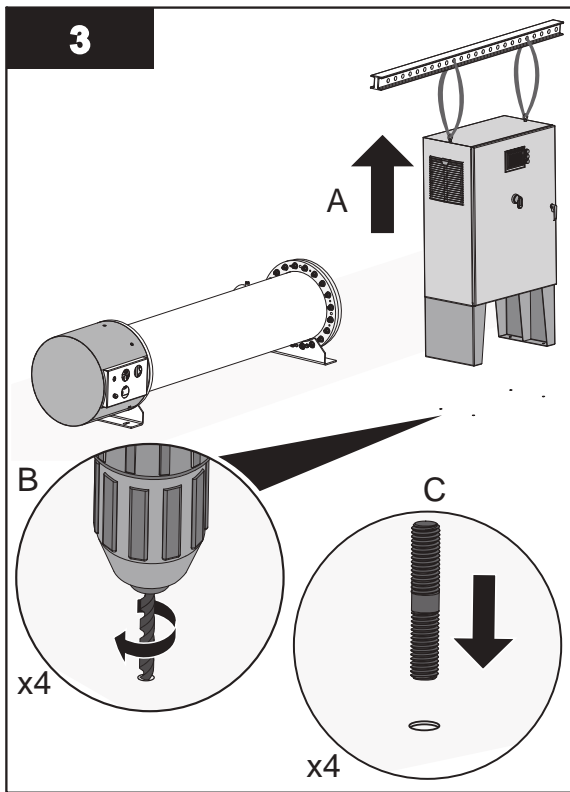

7.4.1 Electrical Connections

Prerequisites:



- Apply lockout tag out devices as necessary. Refer to [Section 4](#).
- Install the UV Chamber(s) - with or without skid. Refer to [Section 7.3](#).
- Install the CPP (for standalone CPP only). Refer to [Section 7.4](#).
- Remove the Service End Cap. Refer to [Section 9.5](#).

Tools:

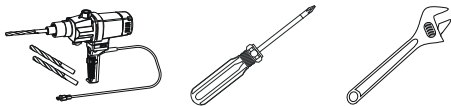

Materials:



- Electrical Drawings (supplied with the system)
- Cable or Wiring Conduit (by others) - Remote CPP only
- Strain Relief – for incoming power (by others)

Procedure:

Note: The CPP provided will be either Local to the Skid or Remote to the Skid. Follow the appropriate instruction below.

7.4.1.1 Local CPP

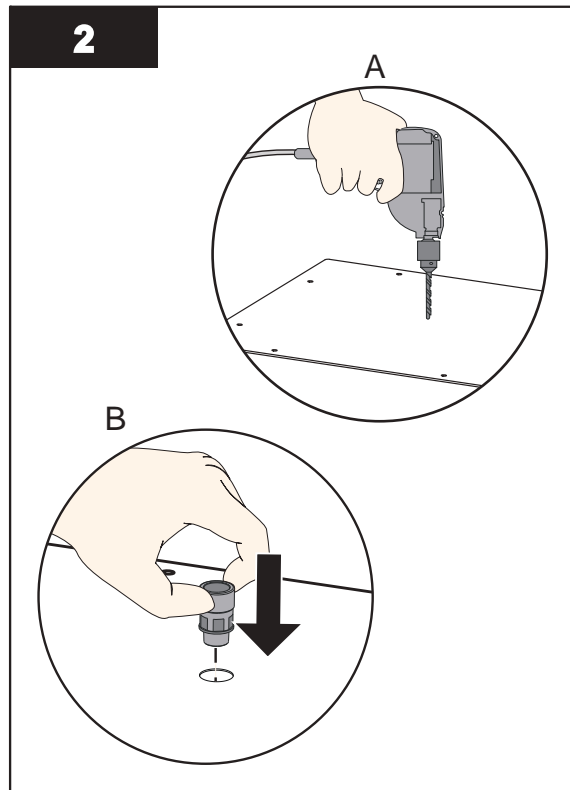
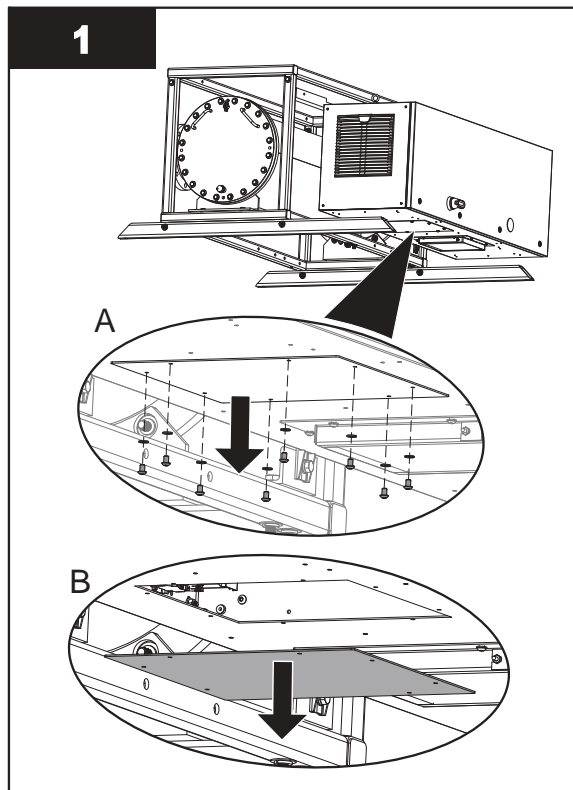

Note: All openings created on the cabinets **MUST** be filled with equipment marked with the same type rating as the enclosure.

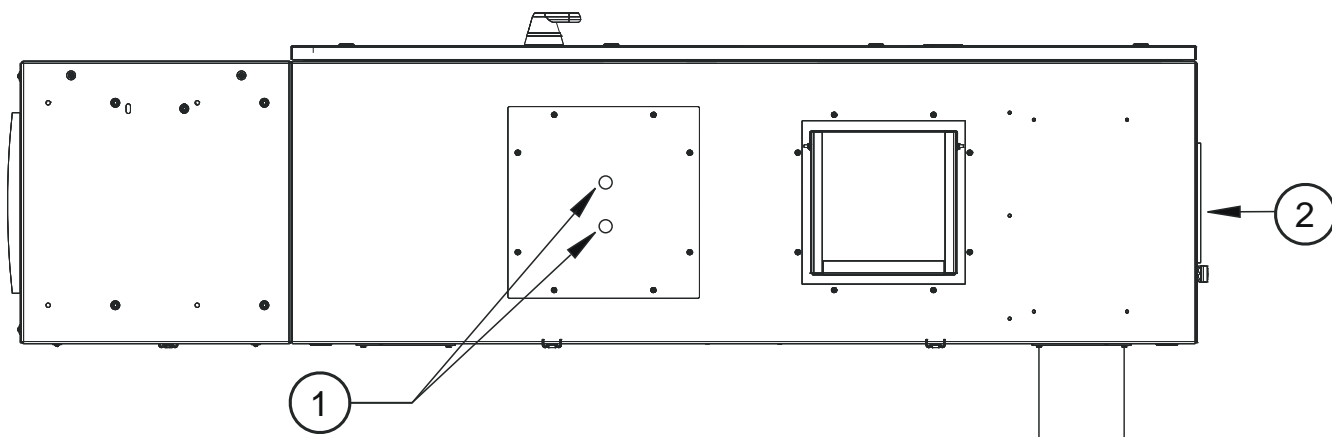

Figure 4 Control Power Panel, Bottom view

1 Cutout for Customer Signal Conduit	2 Front of Control Power Panel (HMI side)
--------------------------------------	---

Note: All openings created on the cabinets **MUST** be filled with equipment marked with the same type rating as the enclosure.

3. Route and terminate AC power to the CPP, matching voltage and power specifications on the serial label of the system. Refer to the wiring diagram to match wire tag numbers.
4. Repeat steps for remaining CPP's.

Installation

7.4.1.2 Remote CPP

7.4.1.2.1 Connect Power from bottom of CPP

1. Remove port plug, and install a strain relief into conduit cutout locations.

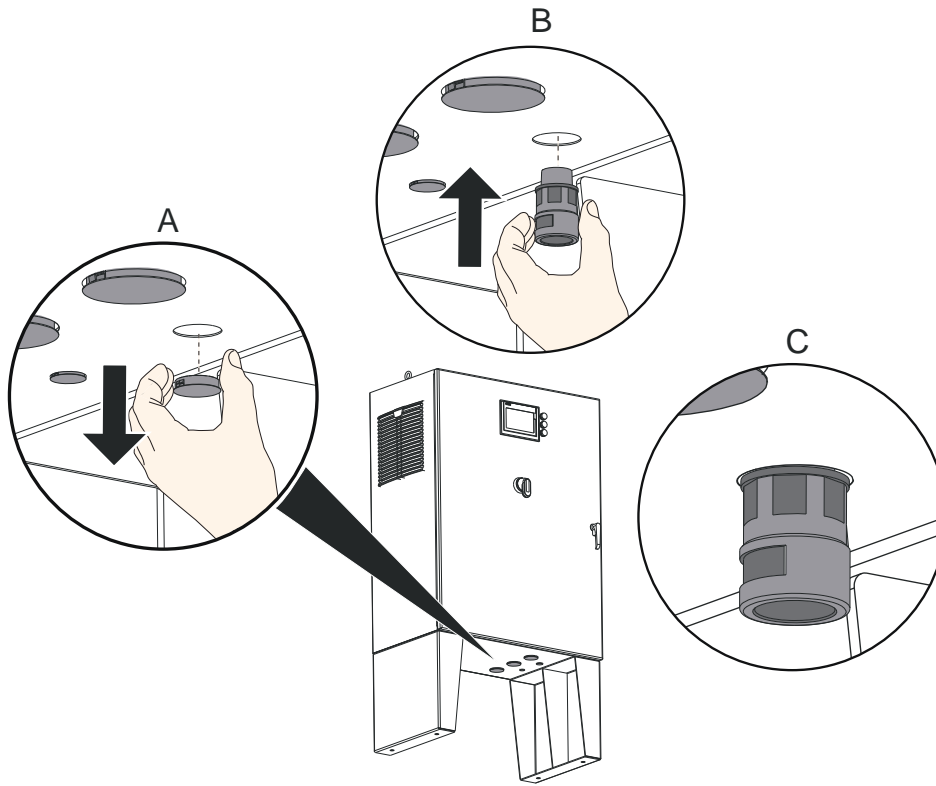

Figure 5 Control Power Panel

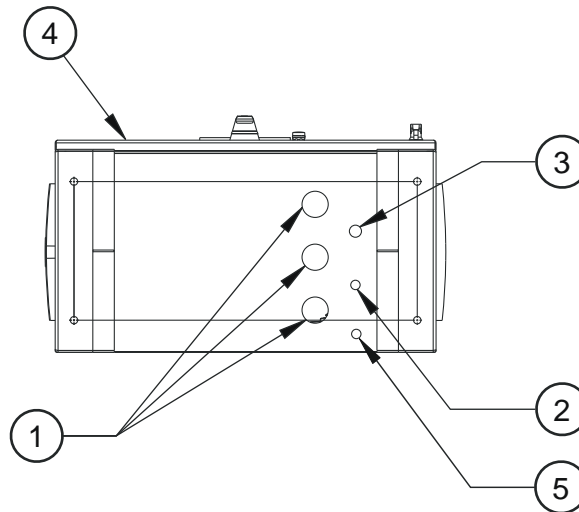

Figure 6 Control Power Panel, Bottom view

1	Cutout for Lamp Cable Conduit	2	Cutout for Instrumentation Wire Conduit
3	Cutout for Customer Signal Conduit	4	Front of Control Power Panel (door)
5	Cutout for Customer Signal Conduit		

Notes: 1) All openings created on the cabinets **MUST** be filled with equipment marked with the same type rating as the enclosure.

2) Unused conduit cutouts to remain sealed with supplied port plugs.

2. Route and terminate AC power to the CPP, matching voltage and power specifications on the serial label of the system. Refer to the wiring diagram to match wire tag numbers. Make sure ground wire is connected to the UV System as per the electrical diagrams.
3. Connect the Lamp Cables to the CPP. The individual lamp connectors are numbered with wire tags for convenient connection; match these numbers to their corresponding number on the UV Chamber end plate.
4. Instrument wiring should reference appropriate wiring diagram. Instrument wiring is based upon customer requirements and installed options. Should your requirements differ, contact your local Aquafine representative or Aquafine Customer Service.

7.4.1.2.2 Connect Power from the top of CPP

1. Drill a hole in the top of the Control Power Panel and install a strain relief.

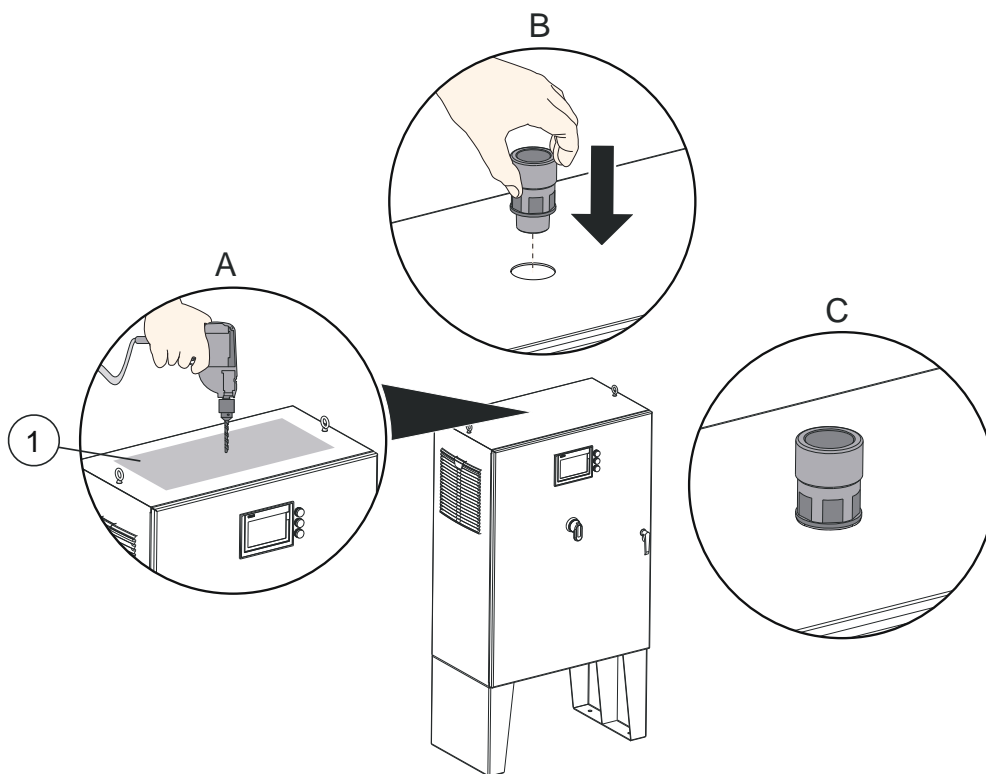

Figure 7 Control Power Panel, Top view

1 Top of Control Power Panel, cutout location

Notes: 1) All openings created on the cabinets **MUST** be filled with equipment marked with the same type rating as the enclosure

2) Unused conduit cutouts on the bottom of the panel to remain sealed with supplied port plugs.

2. Route and terminate AC power to the CPP, matching voltage and power specifications on the serial label of the system. Refer to the wiring diagram to match wire tag numbers. Make sure ground wire is connected to the UV System as per the electrical diagrams.
3. Connect the Lamp Cables to the CPP. The individual lamp connectors are numbered with wire tags for convenient connection; match these numbers to their corresponding number on the UV Chamber end plate.
4. Instrument wiring should reference appropriate wiring diagram. Instrument wiring is based upon customer requirements and installed options. Should your requirements differ, contact your local Aquafine representative or Aquafine Customer Service.

7.5 Assemble the UVI Sensor

Note: Applies to Liquid Sugar applications only.

Prerequisites:

- Remove the UVI Sensor from the plastic bag.

Note: Wear clean cotton or rubber gloves to handle the UVI Sensor. DO NOT contaminate the UVI Sensor window.

Materials:



Procedure:

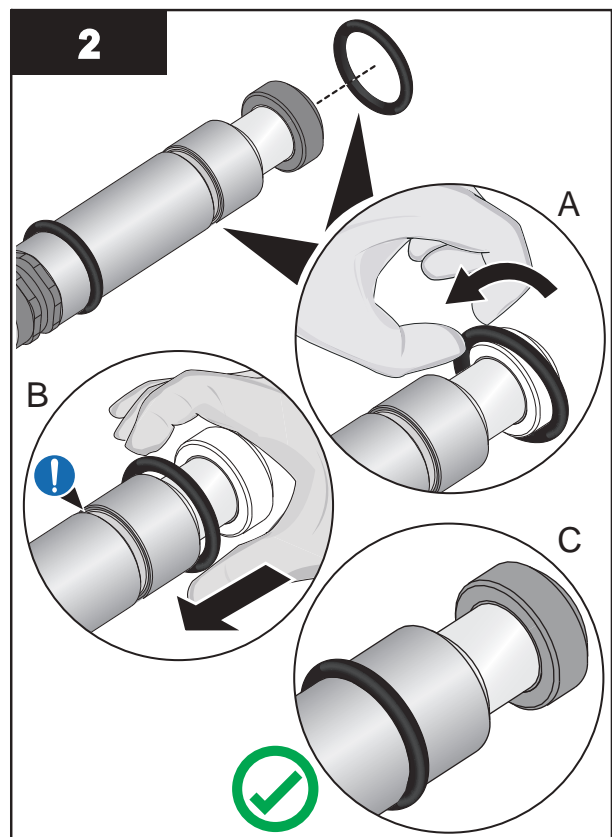
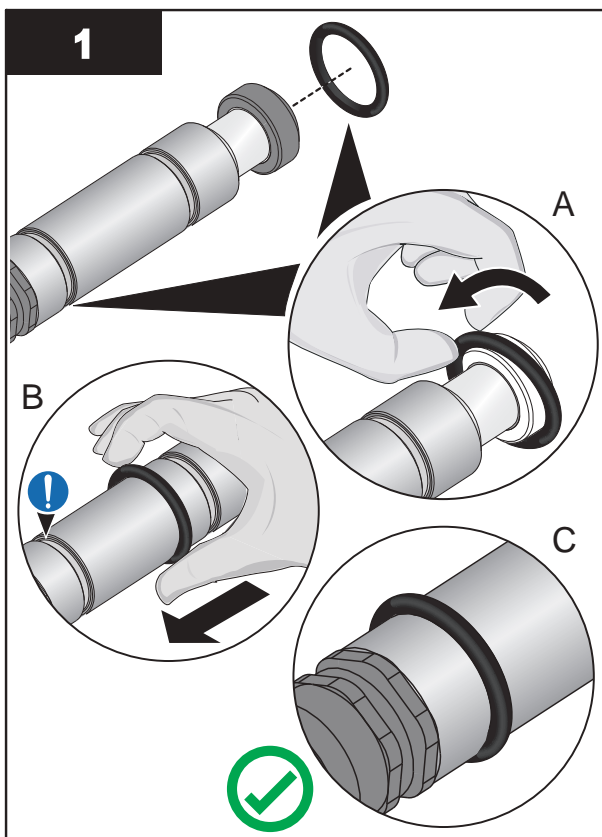

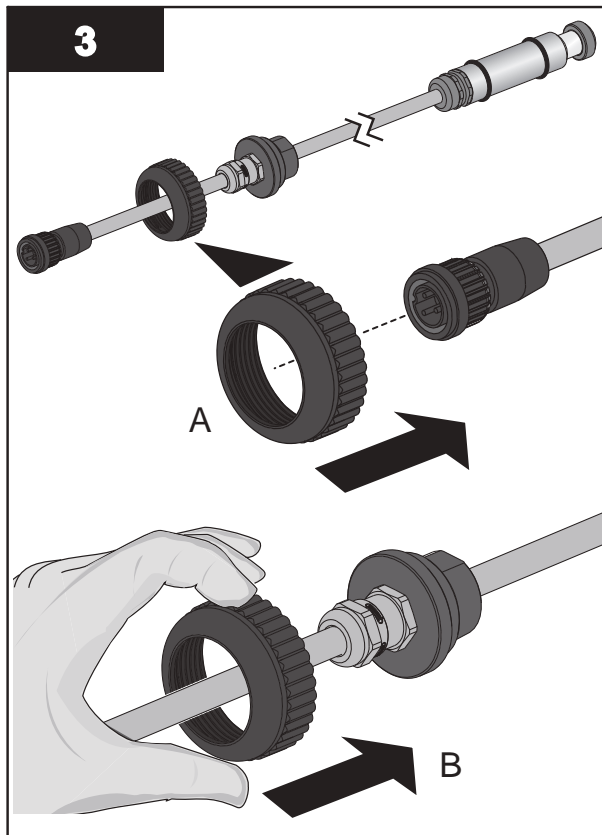

4. Set the UVI Sensor aside.

7.6 Hydrostatic Test

Prerequisites:



- Complete Electrical Connections. Refer to [Section 7.4.1](#).
- Remove UV Lamps (if installed). Refer to [Section 9.6.2](#).
- Remove UVI Sensor. Refer to [Section 9.7.2](#) - **applies to Liquid Sugar systems only**.
- Inspect condition of sleeves for visible cracks or damage. Replace if necessary.
- Make sure the drain valve is closed.

Materials:



Procedure:



1. Fill the UV Chamber with process fluid.
 - a. Stand off to the side and make sure the area is clear of all plant personnel.
 - b. Pressurize the UV Chamber. Refer to [Section 9.4](#).
 - c. Check for leaks.
 - d. Wait twenty minutes.
2. If leaks are found:
 - a. Depressurize and drain the UV Chamber. Refer to [Section 9.3](#).
 - b. Fix the leaks.
 - c. Fill the UV Chamber and do a pressure test. Check for leaks.
3. If there are no leaks, depressurize the UV Chamber. Refer to [Section 9.3](#).
4. Install the UV Lamps. Refer to [Section 9.6.2](#).
5. Install the UVI Sensor. Refer to [Section 9.7.2](#) - *applies to Liquid Sugar systems only*.
6. Install the Service End Cap. Refer to [Section 9.5](#).

Section 8 Operation

⚠ DANGER



Obey all warning and caution statements. Refer to [Section 2](#).

Read and understand this manual before operating this equipment. Read all user documentation before performing operations, inspections, repair, or maintenance on this equipment.



Only competent personnel should undertake operation, repairs, maintenance, or servicing of equipment described in this section of the manual. If you do not understand the information or procedure explanations in this manual, STOP and contact your Service Provider for assistance.

NOTICE

The Microprocessor user interface screens on the CPP vary with the system configuration. The screens described in this section of the manual may not be the same as the screens shown on the CPP.

8.1 User Interface

The Control Power Panel (CPP) contains the control program for the associated UV Chamber. Depending on the UV System configuration, there may be more than one CPP per site. The CPP is configured at the factory with inputs and outputs as required for each system. The manufacturer configures the functionality of each of the signals in the control strategy. Daily operation includes monitoring the system functions and may occasionally require the operator to manually initiate or control processes.

8.1.1 Color Codes and Icons



The User Interface Screens utilize the following color codes within all user screens.

Text Color	Background	Definition
White	Black	Represents static text or numeric data that is unable to be changed by an operator at the current security level.
Black	White	Represents an active button or numeric entry field that will either change the currently displayed screen, or will allow entry of numeric data.

Icon	Text Color	Background			Description
		Color	Gradient	Solid	
	Black	Light Grey	✓	X	Selectable button that will open a pop-up screen or initiate an action.
	Black	Yellow	X	✓	Currently selected option
	Black	Green	X	✓	
	Black	Blue	✓	X	Selectable button that will reset a fault.
	Black	White	X	✓	Return to previous screen.
	--	--	--	--	Indicates that the lamps are warming up.
	White	Red	X	✓	Alarm - Control Action will be taken.

8.1.2 Alarm and Warning Color Codes

The Alarm and Warning indicators are found in the navigation bar. When there is a new alarm or warning, the icon will flash until the user navigates to the Alarm Screen to view the current alarm or warning.

Icon	Icon Color	Definition
	White	Indicates that there are no active warnings or alarms.
	Red	Indicates that there is an active alarm.

8.1.3 User Interface Navigation Bar







The Navigation Bar allows the user to navigate between the different sections of the HMI application.



Figure 8 Navigation Bar

The currently active screen will be indicated by an icon with black background. All others will have white backgrounds.

Table 2 User Interface Navigation

Icon	Screen	Description	Refer:
	System Overview "Home"	The Home Screen is the main System Overview Screen and is designed to provide key system operation information	Section 8.2
	Lamp Status	Displays status of the UV Lamps. From this screen, reset lamp hours and view Lamp and Lamp Driver information.	Section 8.3
	Settings	Allows user to adjust system configuration settings. Note: Setting adjustment is restricted depending on user level login access.	Section 8.4
	Alarms	Displays the current active alarms and allows access to reset alarms. Allows access to Alarm History Screen.	Section 8.5
	Alarm History	Displays the last 256 Historical Alarms	Section 8.5.1
	Information	Allows access to general system information, and set date and time.	Section 8.6

8.1.4 Login Screen

Note: Make sure to log out before leaving the HMI. Push "Logout".

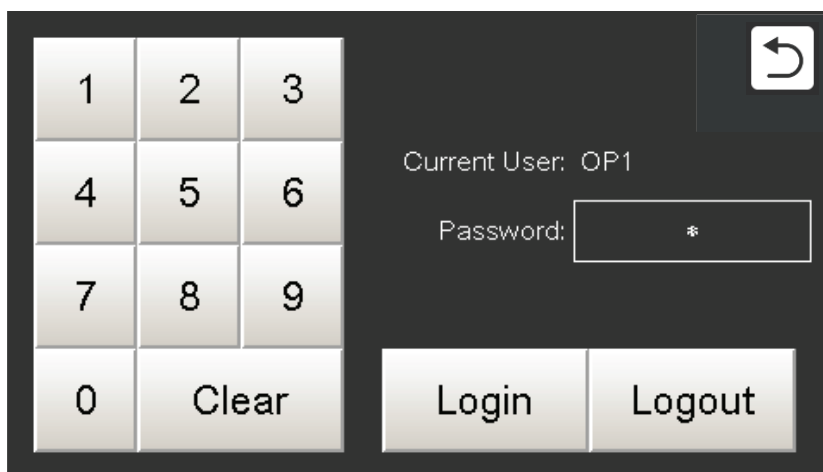

Figure 9 Login Screen

To Login:

1. Press the Login Button in the top right hand corner on any of the main screens.
2. Enter the password.
3. Press Login.

Login Security Levels:

- Not logged in - Screens are display only
- Operator Access - OP (password - 11111)
- Technician Access - OP1 (access provided to approved trained personnel)

8.2 System Overview Screen

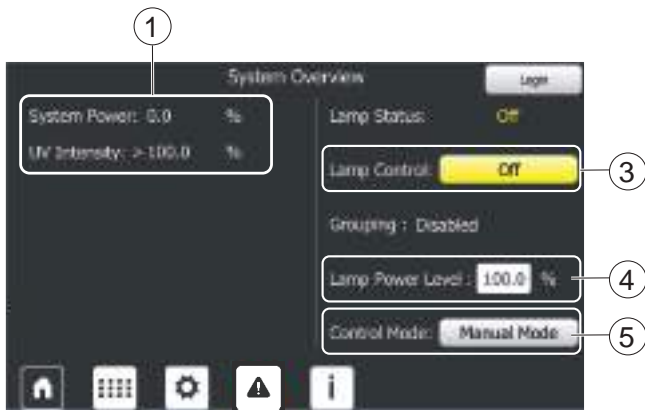

Figure 10 System Overview Local Mode, TOC Application

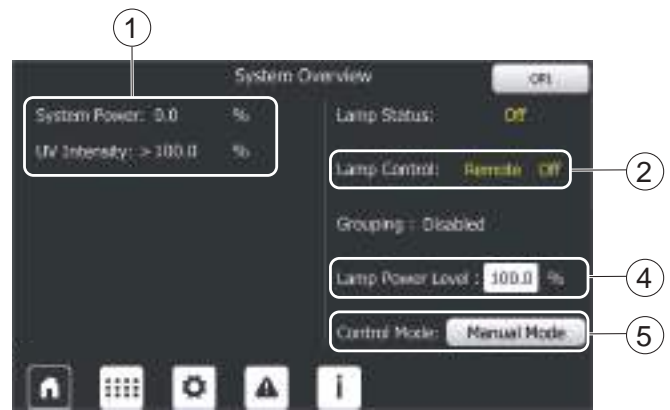

Figure 11 System Overview Remote - Input Mode, TOC Application

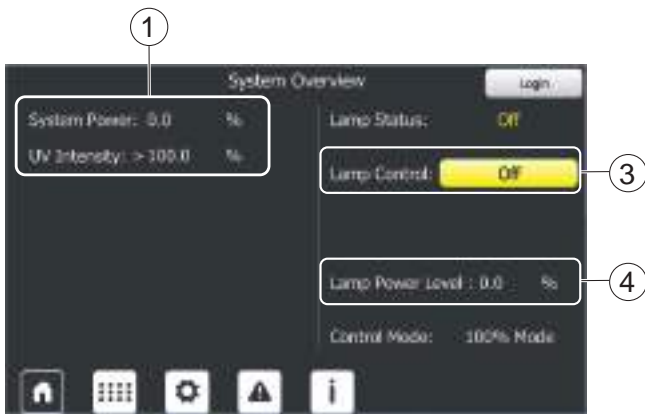

Figure 12 System Overview Local Mode, Non-TOC Application



Figure 13 System Overview Remote - Input Mode, Non-TOC Application



Figure 14 System Overview Remote - Input Mode, Non-TOC Application with Theoretical Dose Option

Item	Description	Refer to:
1	System Status Information	Displays status information about the UV System. Section 8.2.1

Item		Description	Refer to:
2	Remote System Control Message	Displays Remote Command status. Note: Only visible when System Setting "Mode" is set to "Remote - Input" or "Remote - SCADA".	Section 8.2.4
3	Local System Control Buttons	Select to manually turn on/off the UV System. Note: Only visible when System Setting "Mode" is set to "Local".	Section 8.2.3
4	Lamp Power Level	Displays the current Lamp Power Level % set.	--
5	Control Mode	Select to open Control Mode Screen. Allows user to change control mode. Note: Always visible.	Section 8.2.2

8.2.1 System Status Information

Text	Option/Range	Description/Action
Lamp Status	On	Display - UV Lamps are powered on
	On 	Display - UV Lamps are powered on, and warming
	Off	Display - UV Lamps are powered off
Control Mode	100% Mode	Displays the current selected system control mode
	Manual	
Grouping	Enabled	Displays the current grouping selection. Refer to Section 8.2.2.1
	Disabled	
System Power (%)	60 - 100	Displays the current UV System power as a percentage of the total available power with all lamps operating at 100% power. System Power is decreased when lamps are off, or if lamp power level is less than 100%.
UV Intensity (%)	0 - 100%	Displays the current measured UV Intensity value from the UV Intensity sensor as a percentage. Note: System should be operating under normal operating conditions (flow, temperature) with new lamps and clean quartz sleeves.
TOC Actual (ppb)	0.10 - 999.9	Displays the current measured TOC value from the TOC sensor.

8.2.2 Control Mode Screen



Figure 15 Control Mode Screen - 100%



Figure 16 Control Mode Screen - Manual

Control Mode Option	Description
100%	All UV Lamps in UV System will power on and operate at 100% power.

Operation

Control Mode Option	Description
Manual	All UV Lamps in UV System will power on and operate at the entered system power level. Note: "The Low UVI alarm is disabled when lamp power level is lower than 100%" message is only visible when the system is configured with a UVI Sensor.
Grouping	Enabled: Available with 100% or Manual Control Mode enabled. A preset group of UV Lamps in the UV Chamber will be powered on while the remaining group of UV Lamps in the UV Chamber will be powered off. The preset grouping options are available on the HMI screen. Disabled: All of the UV Lamps in the UV Chamber will be powered On or Off together and will operate at the same power level.

Change the Control Mode

1. System Overview Screen → Select the Control Mode Button → Select a control mode → Press the Return button when finished.

8.2.2.1 Grouping Settings

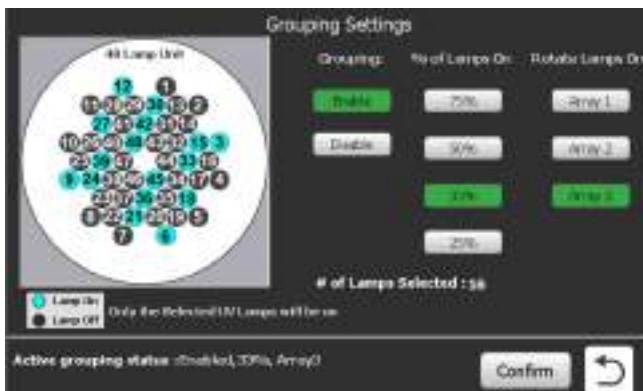

Figure 17 Grouping Settings (Enabled)

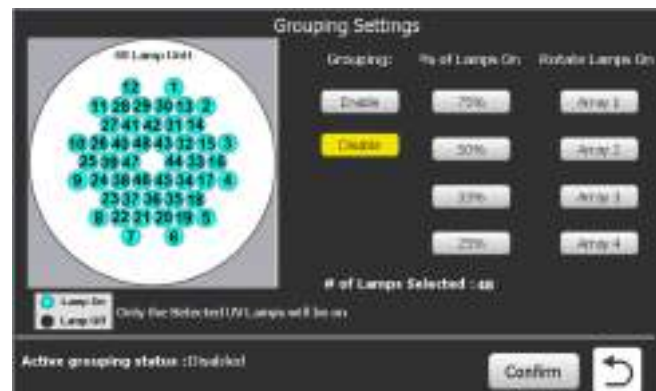

Figure 18 Grouping Settings (Disabled)

Enable or Disable Grouping

1. Set the control mode to either 100% or Manual (refer to [Figure 15](#) and [Figure 16](#)).
2. Select the Grouping button (refer to [Figure 15](#) and [Figure 16](#)) to open the Grouping Settings Screen.
3. Select 'Enable' to enable Grouping or 'Disable' to disable Grouping.
4. Select the 'Confirm' button to accept the change.

Assign grouping:

1. Set the control mode to either 100% or Manual (refer to [Figure 15](#) and [Figure 16](#)).
2. Select the Grouping button (refer to [Figure 15](#) and [Figure 16](#)) to open the Grouping Settings Screen.
3. Enable Grouping → Select 'Enable'.
4. Select the % of Lamps on (i.e. 25%, 33%, 50% or 75%).
5. Select the Rotate Lamps On array (Array 1, Array 2 etc.).

Notes: 1) The number of array options vary by "% of Lamps On" selection.

2) The lamp array graphic will dynamically update, displaying which UV Lamps will be powered 'On' (cyan) and which UV Lamps will be powered 'Off' (dark grey).

6. Select the 'Confirm' button to confirm 'Grouping Settings'.
 - a. Select 'No' to reject the changes and return to the Grouping Settings Screen.
 - b. Select 'Yes' to accept the changes.
7. Select the Return button when assignments are confirmed to return to the Control Mode Screen.

8.2.3 Local System Control Buttons

The Local System Control Buttons will only be visible when the System Setting "Mode" is set to "Local".

Item	Button	Description
Local System Control	On/Off	Manually turn on or off the UV System. The displayed button text indicates the current state of the control command (on or off)

8.2.4 Remote Control Mode Message

The Remote Control Mode Message will only be visible when the System Setting "Mode" is set to "Remote - Input" or "Remote - SCADA".

Message:	Displays when:
Remote On	The system is in "Remote - Input" Control Mode, and the discrete input run signal is on, or the system is in "Remote - SCADA" and the designated signal from SCADA is on.
Remote Off	The system is in "Remote - Input" Control Mode, and the discrete input run signal is off, or the system is in "Remote - SCADA" and the designated signal from SCADA is off.

8.3 Lamp Status Screen

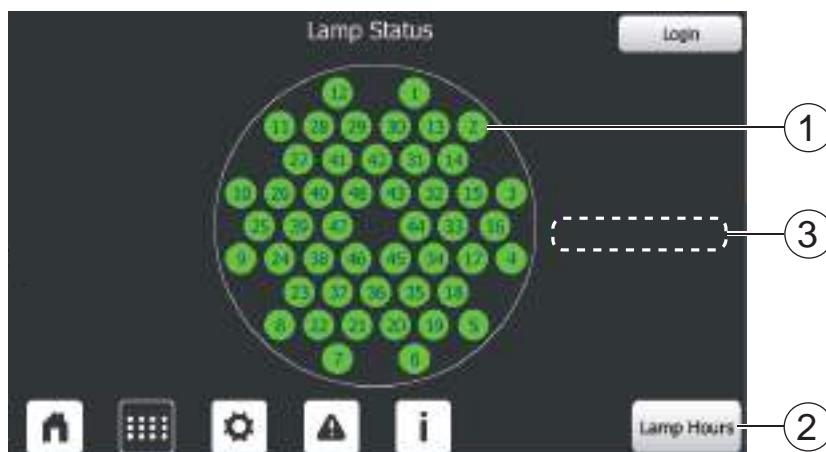

Figure 3 Lamp Status Screen

Item	Button/Icon	Color	Description/Action	Refer:
1		Grey	UV Lamp is off. Select icon to open Lamp and Driver Information Screen	Section 8.3.1
		Green	UV Lamp is on and healthy. Select icon to open Lamp and Driver Information Screen	Section 8.3.1
		Red	UV Lamp is unhealthy. Select icon to open Lamp and Driver Information Screen	Section 8.3.1

Operation

Item	Button/Icon	Color	Description/Action	Refer:	
2	Lamp Hours Screen	Lamp Hours	--	Select to access the Lamp Hours Screen.	Section 8.3.4
3	Lamp Hours Approaching End of Life Notification	--	--	The Lamp Hours Approaching End of Life notification will be visible when a UV Lamp runtime has reached 8,200 runtime hours and will remain in place until the UV Lamp is replaced. It is recommended to order a new UV Lamp at this time.	--

8.3.1 Lamp and Driver Information Screen

Note: This screen is displayed by pressing on any UV Lamp icon on the Lamp Status screen ([Figure 3](#)).



Figure 4 Lamp and Driver Information Screen - Active Lamp Fault Condition



Figure 5 Lamp and Driver Information Screen - Active Lamp Driver Fault Condition

Item	Definition/Action	Refer:
1	Alarm Notification Note: UV Lamps will only display alarms, Lamp Drivers will display alarms and warnings.	Section 8.1.2
2	Lamp Number / Status Displays the status for the selected UV Lamp (i.e On or Off) To select a different UV Lamp, enter the required Lamp Number into the numeric entry field.	--
3	Lamp and Lamp Driver Information Displays information for the selected UV Lamp and Lamp Driver.	Section 8.3.2
4	Lamp Driver Identification Displays the Lamp Driver identification number for the selected UV Lamp.	--

Item		Definition/Action	Refer:
5	Reset Hours Button	Select to reset lamp hours for the selected UV Lamp.	Section 8.3.4
6	Driver Fault Reset Button	Select to reset a fault for the selected Lamp Driver. Note: The button is visible only when there is an active driver fault.	Section 8.3.3

8.3.2 Lamp and Lamp Driver Information

Text	Definition
Voltage	Displays the Lamp Voltage (V) for the selected UV Lamp. The status is provided by Lamp Driver.
Current	Displays the Lamp Current (mA) for the selected UV Lamp. The status is provided by Lamp Driver.
Lamp Power	Displays the Lamp Power in Watts (W) for the selected UV Lamp. The status is provided by the Lamp Driver.
Daily Restarts	Displays the total number of daily restarts for the selected UV Lamp. The value is calculated in the PLC.
Life Restarts	Displays the total number of restarts over the lifetime of the selected UV Lamp. The value is calculated in the PLC.
Hours of Operation	Displays the total hours of operation for the selected UV Lamp. The value is calculated in the PLC.
Driver Power	Displays the current Lamp Driver Power in Watts (W). The status is provided by Lamp Driver.
Driver System Status	Okay - Driver is healthy
	Error - Driver is faulted, message triggered by a system level Driver Fault.

8.3.3 Reset a Lamp Driver Fault

1. Lamp Status Screen → Select a UV Lamp associated with the faulted driver.
2. Lamp and Driver Information Screen → Press Driver Fault Reset.

8.3.4 Reset Lamp Hours

Individual Lamp Hours may be reset from either the Lamp and Driver Information Screen ([Section 8.3.1](#)) or from the Lamp Hours Screen ([Figure 6](#)). “Reset all Lamp Hours” is reset from the Lamp Hours Screen only.

Note: The Daily and Life Restarts for the selected UV Lamp(s) will be reset when Lamp Hours are reset.

Reset lamp hours from the Lamp and Driver Information Screen:

1. Lamp and Driver Information Screen → Select the 'Reset Hours' button.
2. Reset Hours Confirmation Pop-Up Screen → Select 'Yes' to reset the hours or 'No' to cancel.